



ThinkEdge SE30n Gen2

设置、安全与保修指南

Setup, Safety and Warranty Guide

For Barcode Position Only

中国印刷

PN: SP41U43190

<https://smartsupport.lenovo.com>

Lenovo

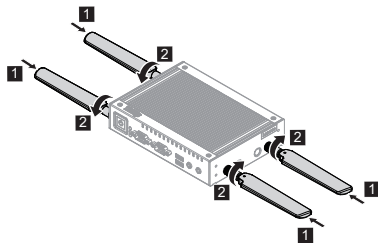
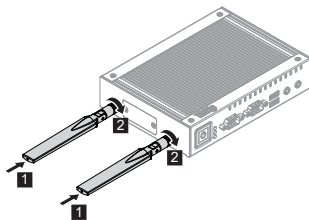
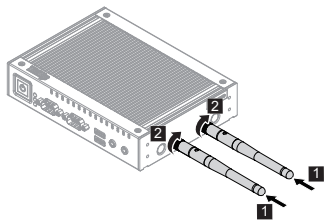

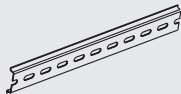
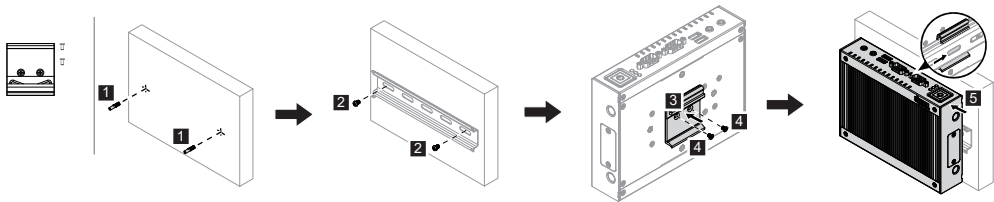
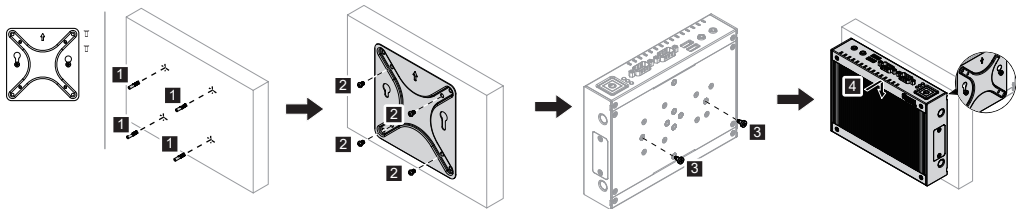

请在安装 DIN 支架套件之前准备好导轨。
Prepare a rail before installing the DIN bracket kit.

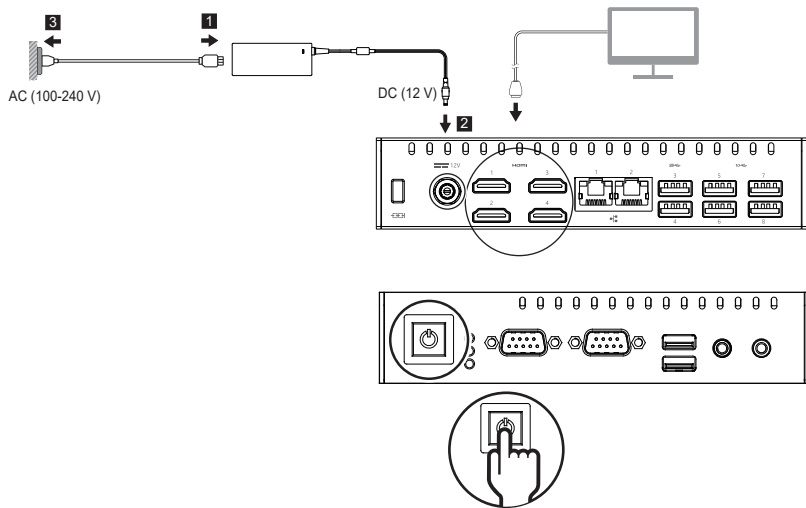

自定义计算机 | Customize your computer

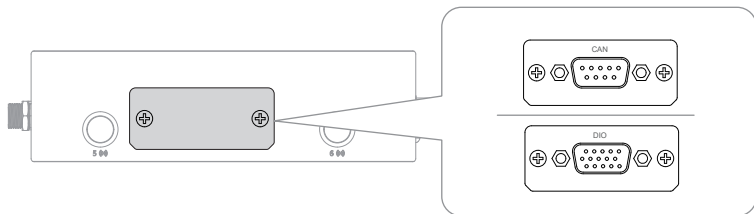

您可以配置可自定义的接口以支持多种设备，包括但不限于：

You can configure the customizable connectors to support devices, including but not limited to the following:



安全信息



塑料袋声明

危险：塑料袋具有危险性。请将塑料袋放在婴儿和儿童接触不到的位置，以避免窒息危险。

常规电池声明（适用于特定型号）

危险：

Lenovo 提供的用于产品的电池已经过兼容性测试，并应该仅用核准的部件进行更换。非 Lenovo 指定的电池或经过拆卸或改装的电池不在保修范围之内。

电池使用不当或错误操作可能导致电池过热、漏液或爆炸。为避免可能造成的伤害，请注意以下几点：

- 请勿打开、拆开或维修任何电池。
- 请勿挤压或刺穿电池。
- 请勿使电池短路、接触水或其他液体。
- 使电池远离儿童。
- 使电池远离火源。

如果电池损坏，或发现从电池中流出异物或电池引线上堆积异物，请停止使用电池。

请在室温下存放可充电电池或含有可充电电池的产品，并将电池电量充至大约 30% 到 50%。建议每年对电池充电一次以防止过电量放电。

请勿将电池丢入以掩埋方式处理的垃圾中。处理电池时，请遵守当地的法令或法规。

内置充电电池声明（适用于特定型号）

危险：

请勿尝试拆卸或更换内置可充电电池。必须由 Lenovo 授权维修机构、技术人员或独立的有资质的专业人员更换电池。只能严格按照产品文档中包含的说明对电池进行充电。

经 Lenovo 授权的维修机构或技术人员将根据当地的法律法规回收 Lenovo 电池。

纽扣锂电池声明（适用于特定型号）

危险：如果电池更换不当会有爆炸危险。

如果纽扣电池不是 CRU，请勿尝试更换纽扣电池。必须由 Lenovo 授权维修机构或技术人员更换电池。

经 Lenovo 授权的维修机构或技术人员将根据当地的法律法规回收 Lenovo 电池。本产品包含纽扣电池。更换纽扣锂电池时，请仅使用相同类型的电池或制造商推荐同类电池。该电池中含有锂，如果使用、操作或处理不当，可能会发生爆炸。误吞纽扣锂电池或将电池置入身体的任何部位都会引起窒息或在短短两小时内造成体内严重烧伤，甚至导致死亡。

请勿吞入电池。化学烧伤危险。请勿让儿童接触电池。如果电池仓无法牢固关闭，请停止使用产品并将其放置在远离儿童的地方。如果吞下了纽扣锂电池或其进入了身体的任何部位，请立即就医。

请勿：

- 将电池投入或浸入水中
- 加热至超过 100°C (212°F)
- 修理或拆开电池
- 放置在极低的气压环境中
- 放置在极高的温度环境中
- 挤压、穿刺、切削或焚烧

请按照当地的法令法规要求处理电池。

以下声明适用于美国加利福尼亚州的用户。

加利福尼亚州高氯酸盐相关信息：

使用二氧化锰纽扣锂电池的产品可能含有高氯酸盐。

高氯酸盐材料 - 可能需要采取特殊的处理方法，请参阅 <https://www.dtsc.ca.gov/hazardouswaste/perchlorate>

激光安全信息（适用于特定型号）

警告：

装有激光产品（如 CD-ROM、DVD 驱动器、光纤设备或发射器）时，请注意以下情况：

- 请勿卸下外盖。卸下激光产品的外盖可能会导致遭受危险的激光辐射。设备中没有可维修的部件。
- 进行此处未指定的控制或调整，或执行此处未指定的操作步骤，可能会导致遭受危险的辐射。

危险：

某些激光产品包含嵌入式 3A 类或 3B 类激光二极管。请注意以下情况：

打开时有激光辐射。请勿直视光束以及使用光学仪器直接观看，并且要避免直接受到激光束照射。

保修和支持信息

保修信息

适用于您产品的具体保修信息见产品随附保修文件。您也可登录联想官方网站，从网页底部点击 [保修配置查询](#)，然后按屏幕提示查看产品及其部件的保修状态。网站上的保修信息仅为为用户方便目的提供，如与产品随附保修文件不一致，以产品随附保修文件为准。

产品保修依联想保修条款提供。《联想产品标准保修承诺》（版本 LW-GEN-140106）适用于中国大陆地区销售的产品，该保修条款随产品附带或通过联想官网提供，您可登录联想官网，在网页底部点击 [服务政策查询](#) 查看联想保修政策条款。某些全球销售的产品，在首次开机设置时可能会显示联想有限保证条款（LLW），该条款仅适用于在中国大陆地区境外销售的产品，如您的产品在中国大陆地区购买，您可忽略该条款。

恢复信息

您的计算机可能未附带 Windows® 全套恢复光盘或恢复 U 盘。要恢复 Microsoft® Windows 操作系统，请参阅《用户指南》中的恢复信息。

访问《用户指南》

您可登录联想官网，进入服务频道点击**用户手册查询**，查阅适用您产品的用户指南及其他使用说明文件。

获得支持

我们的保修和服务联络信息见产品随附保修文件，或登录联想官网从网页底部点击**联系我们**查询。您也可至联想官网“服务”频道获得更多支持服务信息。

联想官网

<https://www.lenovo.com.cn>

合规性、回收和环境信息

合规性信息

本节提供特定国家或地区的合规性信息。最新版本的合规性信息位于 <https://www.lenovo.com/compliance>。

法规信息标签

可以通过产品、产品包装上的物理标签提供贵政府要求的信

息，或以电子方式将其显示在电子标签屏幕上。

要访问电子标签屏幕，请重新启动计算机。显示徽标屏幕时，请按 F9 键或点击提示进入 Startup Interrupt 菜单，然后点击“法规信息”选项。

回收和环境信息

本节提供特定国家或地区的回收与环境信息。

注：产品无任何外接输入电源相连时，关机状态下不再耗用外部电源。

Lenovo 鼓励信息技术 (IT) 设备的所有者负责将不再使用的产品回收。Lenovo 提供多种计划和服务，以帮助设备所有者对他们的 IT 产品进行回收。有关回收 Lenovo 产品的信息，请访问 <https://www.lenovo.com/recycling>。

有关其他回收和环境声明，请参阅《常规安全和合规性声明》。可从以下网址获得有关我们产品的最新环境信息：
<https://www.lenovo.com/ecodeclaration>

中国大陆的回收信息

《废弃电器电子产品回收处理管理条例》提示性说明

联想鼓励拥有联想品牌产品的用户当不再需要此类产品时，遵守国家废弃电器电子产品回收处理相关法律法规，将其交给当地具有国家认可的回收处理资质的厂商进行回收处理。更多回收服务信息，请点击进

<https://support.lenovo.com.cn/activity/551/htm>。

中国大陆有害物质限制 (RoHS) 指令

产品中有害物质的名称及含有信息表，请通过以下网站进行查询：
https://iknow.lenovo.com.cn/detail/dc_191404.html

LENOVO 和 LENOVO 徽标都是 Lenovo 的商标。Microsoft 和 Windows 是 Microsoft 公司集团的商标。其他商标的所有权归其各自所有者所有。

有关其他法律声明，请访问 https://iknow.lenovo.com.cn/detail/dc_191404.html 参阅适用于您计算机的《常规安全和合规性声明》。

Safety information



Plastic bag notice

DANGER: Plastic bags can be dangerous. Keep plastic bags away from babies and children to avoid danger of suffocation.

General battery notice (for selected models)

DANGER:

Batteries supplied by Lenovo for use with your product have been tested for compatibility and should only be replaced with approved parts. A battery other than the one specified by Lenovo, or a disassembled or modified battery is not covered by the warranty.

Battery abuse or mishandling can cause overheating, liquid leakage, or an explosion. To avoid possible injury, do the following:

- Do not open, disassemble, or service any battery.
- Do not crush or puncture the battery.
- Do not short-circuit the battery, or expose it to water or other liquids.
- Keep the battery away from children.
- Keep the battery away from fire.

Stop using the battery if it is damaged, or if you notice any discharge or the buildup of foreign materials on the battery leads.

Store the rechargeable batteries or products containing the rechargeable batteries at room temperature, charged to approximately 30% to 50% of capacity. We recommend that the batteries be charged about once per year to prevent overdischarge.

Do not put the battery in trash that is disposed of in landfills. When disposing of the battery, comply with local ordinances or regulations.

Notice for removable rechargeable battery (for selected models)

DANGER:

Only recharge the battery strictly according to instructions included in the product documentation.

If the battery is incorrectly replaced, there is danger of an explosion. The battery contains a small amount of harmful substance.

Notice for built-in rechargeable battery (for selected models)

DANGER:

Do not attempt to remove or replace the built-in rechargeable battery. Replacement of the battery must be done by a Lenovo-authorized repair facility, technician, or an independent qualified professional.

Only recharge the battery strictly according to instructions included in the product documentation.

The Lenovo-authorized repair facilities or technicians recycle Lenovo batteries according to local laws and regulations.

Lithium coin-cell battery notice (for selected models)

DANGER: Danger of explosion if battery is incorrectly replaced.

If the coin-cell battery is not a CRU, do not attempt to replace the coin-cell battery. Replacement of the battery must be done by a Lenovo-authorized repair facility or technician.

The Lenovo-authorized repair facilities or technicians recycle Lenovo batteries according to local laws and regulations. This product contains a coin cell battery. When replacing the lithium coin-cell battery, use only the same type or equivalent type that is recommended by the manufacturer. The battery contains lithium and can explode if not properly used, handled, or disposed of. Swallowing the lithium coin-cell battery or placing it inside any part of the body will cause choking or severe internal burns in just two hours and might even result in death.

Do not ingest the battery. Chemical Burn Hazard. Keep batteries away from children. If the battery compartment does not close securely, stop using the product and keep it away from children. If the lithium coin-cell battery is swallowed or placed inside any part of the body, seek medical care immediately.

Do not:

- Throw or immerse into water
- Heat to more than 100°C (212°F)
- Repair or disassemble
- Leave in an extremely low air pressure environment
- Leave in an extremely high-temperature environment
- Crush, puncture, cut, or incinerate

Dispose of the battery as required by local ordinances or regulations.

The following statement applies to users in the state of California, U.S.A.

California Perchlorate Information:

Products containing manganese dioxide lithium coin-cell batteries may contain perchlorate.

Perchlorate Material - special handling may apply, see <https://www.dtsc.ca.gov/hazardouswaste/perchlorate>

Laser safety information (for selected models)

CAUTION:

When laser products (such as CD-ROMs, DVD drives, fiber optic devices, or transmitters) are installed, note the following:

- Do not remove the covers. Removing the covers of the laser product could result in exposure to hazardous laser radiation. There are no serviceable parts inside the device.
- Use of controls or adjustments or performance of procedures other than those specified herein might result in hazardous radiation exposure.

DANGER:

- Some laser products contain an embedded Class 3A or Class 3B laser diode. Note the following:
- Laser radiation when open. Do not stare into the beam, do not view directly with optical instruments, and avoid direct exposure to the beam.

Warranty and support information

Warranty Information

Lenovo provides a warranty period for your computer. Read the Lenovo Limited Warranty (LLW) at https://www.lenovo.com/warranty/llw_02.

To check the warranty status of your computer or purchase upgrades, go to <https://pcsupport.lenovo.com/warrantylookup>, and then follow the on-screen instructions.

Recovery information

Your computer might not come with a Windows® recovery disc set or USB key. To restore the Microsoft® Windows operating system, see the recovery information in the *User Guide*.

Access *User Guide*

1. Go to <https://pcsupport.lenovo.com>.
2. Follow the on-screen instruction to access the *User Guide* for your product.

Get support

You can also get the most up-to-date telephone number for the Customer Support Center from <https://pcsupport.lenovo.com/supportphonenumber>.

To get more support options from Lenovo, go to <https://pcsupport.lenovo.com/contactus>.

Compliance, recycling, and environmental information

Compliance information

This section shows the compliance information for specific countries or regions. The latest compliance information is available at <https://www.lenovo.com/compliance>.

Regulatory labels

Your government-required information may be provided through a physical label on the product, the product packaging, or displayed electronically on the E-label screen.

To access the E-label screen, restart the computer. When the logo screen is displayed, press F9, or tap the prompt to enter the Startup Interrupt menu and the Regulatory Information option subsequently.

Recycling and environmental information

This section shows the recycling and environmental information for specific countries or regions.

Lenovo encourages owners of information technology (IT) equipment to responsibly recycle their equipment when it is no longer needed. Lenovo offers a variety of programs and services to assist equipment owners in recycling their IT products. For information on recycling Lenovo products, go to <https://www.lenovo.com/recycling>.

For additional legal notices, refer to the https://pcsupport.lenovo.com/docs/generic_notices for your computer.



扫描《用户指南》QR 码，了解有关该产品的更多信息。
Scan the *User Guide* QR code to learn more information about the product.



Win11 IoT Enterprise 2024 LTSC

https://learn.microsoft.com/windows/iot/iot-enterprise/getting_started

Ubuntu Server / Core

<https://documentation.ubuntu.com/server>

<https://documentation.ubuntu.com/core>

For FSC Mix logo only

First Edition (January 2026)
© Copyright Lenovo 2026.

LENOVO, LENOVO logo, ThinkEdge, and ThinkEdge logo are trademarks of Lenovo. The terms HDMI and HDMI High-Definition Multimedia Interface are trademarks or registered trademarks of HDMI Licensing LLC in the United States and other countries. All other trademarks are the property of their respective owners.

LIMITED AND RESTRICTED RIGHTS NOTICE: If data or software is delivered pursuant to a General Services Administration "GSA" contract, use, reproduction, or disclosure is subject to restrictions set forth in Contract No.GS-35F-05925.



Reduce
Reuse
Recycle