

# ergotron®

---

## Handle for LX Dual Direct

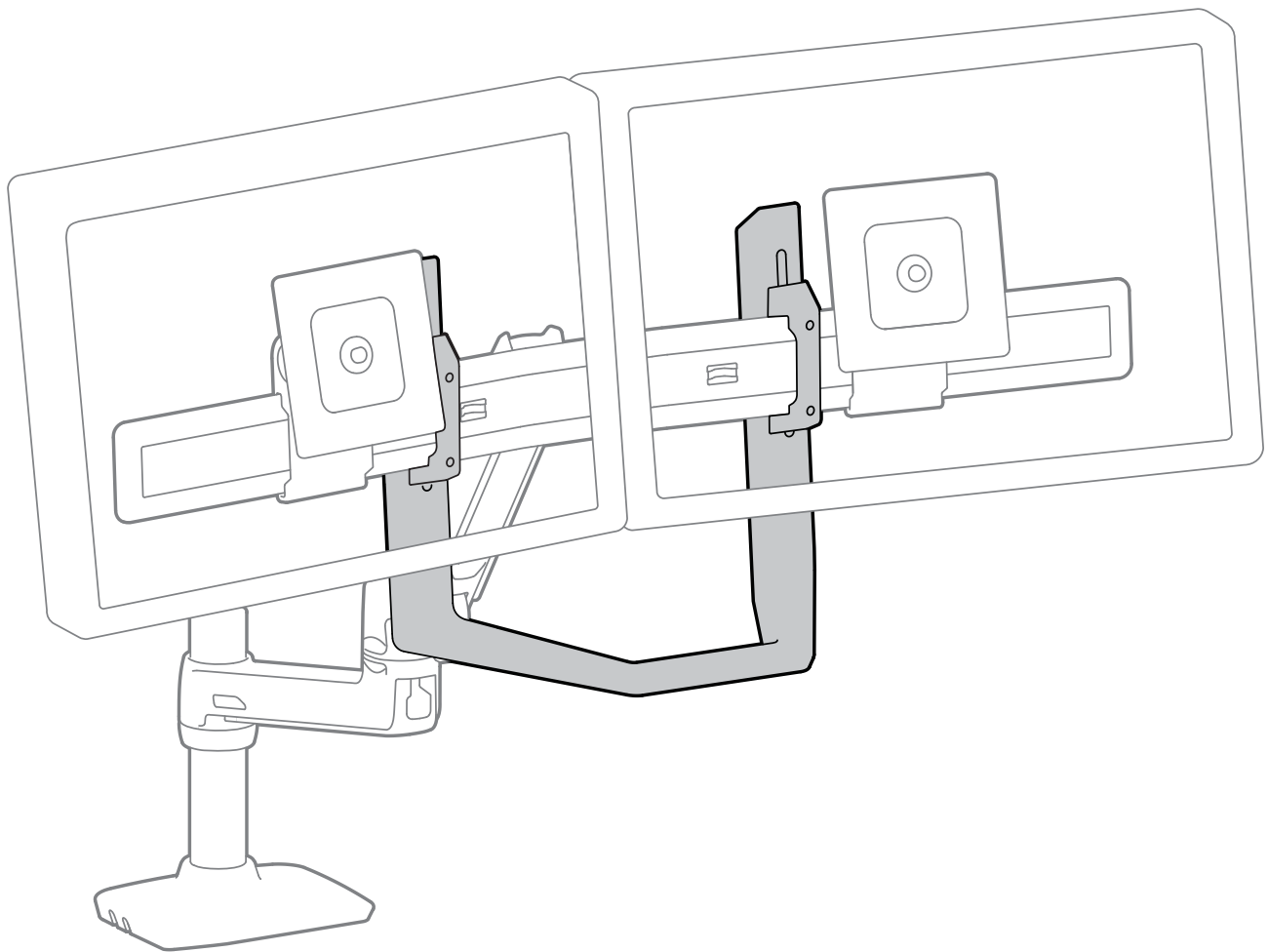

---

**English**





For the latest User Installation Guide please visit: [www.ergotron.com](http://www.ergotron.com)

English, Español, Français, Deutsch, Nederlands, Italiano, Svenska, 日本語, 汉语

[www.ergotron.com](http://www.ergotron.com) | USA: 1-800-888-8458 | Europe: +31 (0)33-45 45 600 | China: 400-120-3051 | Japan: [japansupport@ergotron.com](mailto:japansupport@ergotron.com)

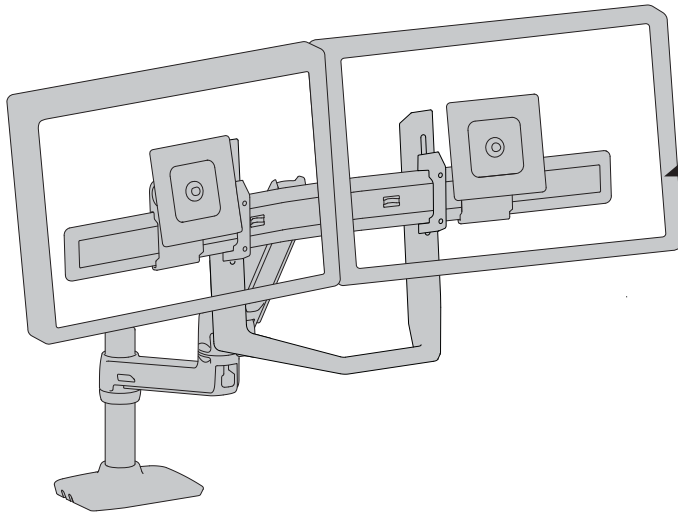

# Features & Specifications



 ≤ 11lbs. (5 kg)

 CAUTION: DO NOT EXCEED MAXIMUM LISTED WEIGHT CAPACITY. SERIOUS INJURY OR PROPERTY DAMAGE MAY OCCUR!

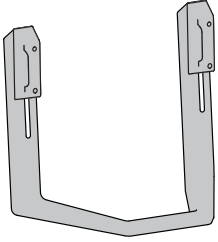
## Components

	A	B
1	1x 	1x  4 mm



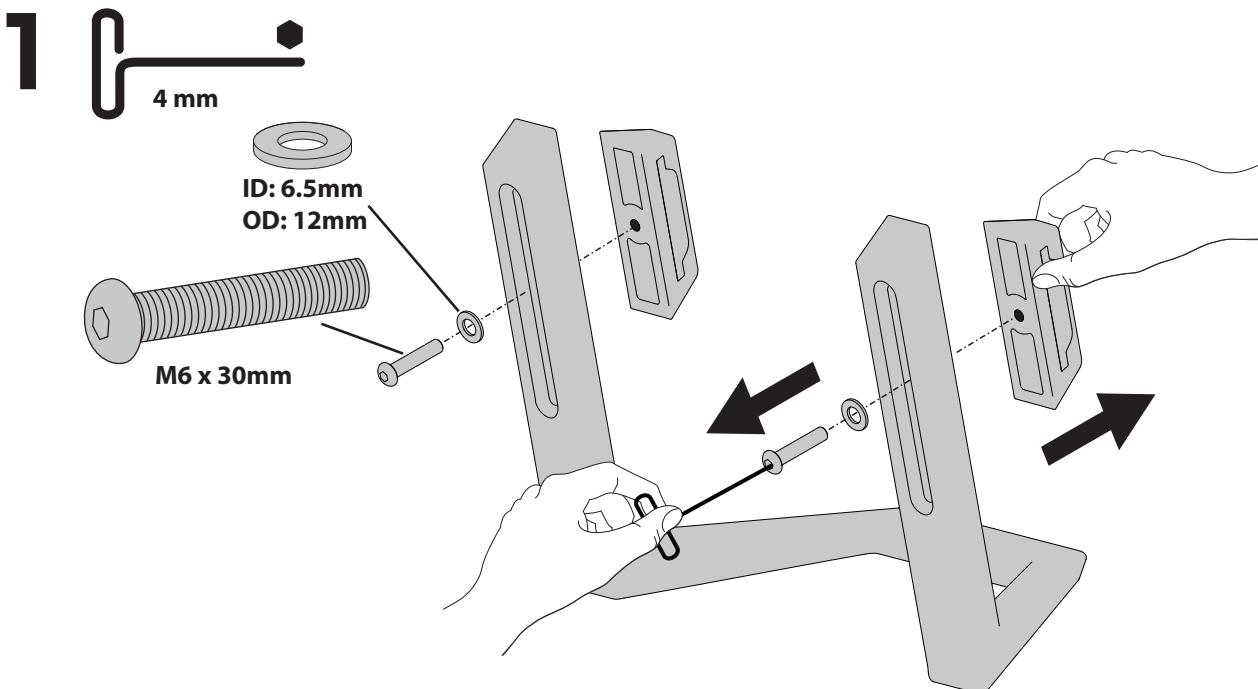

## Tools Needed

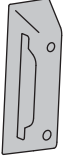

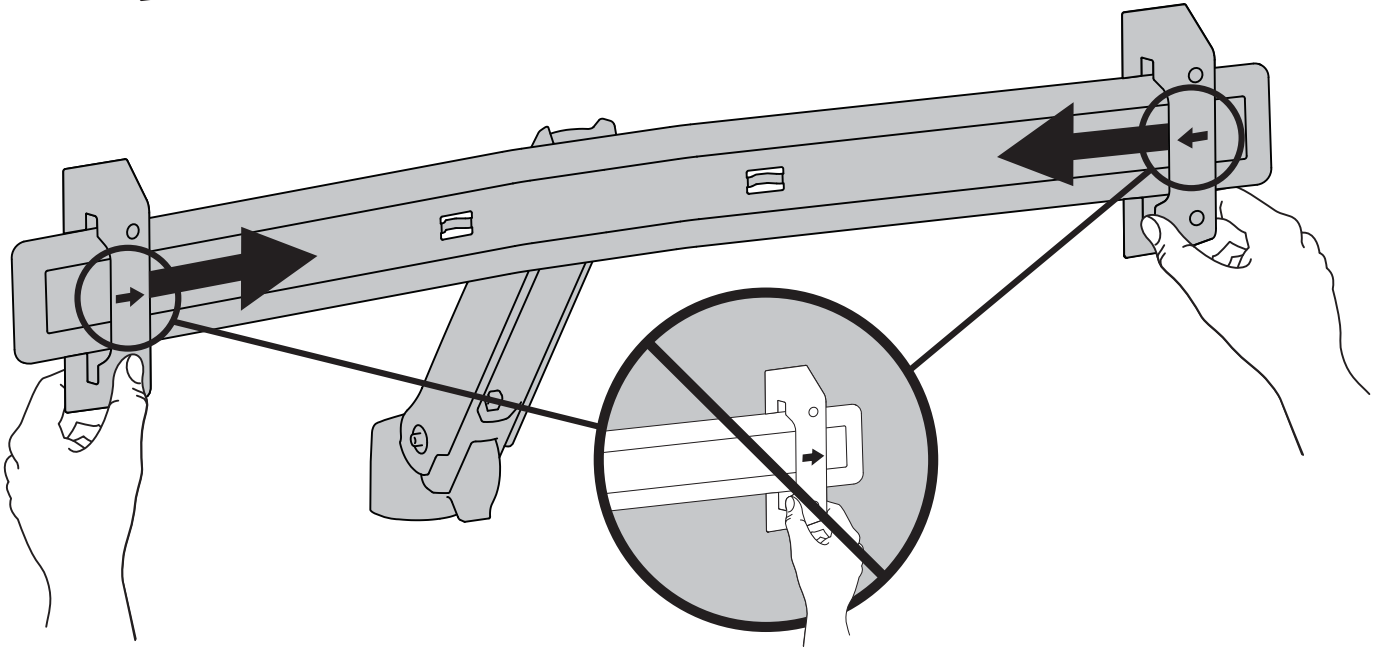
**2** 2x 

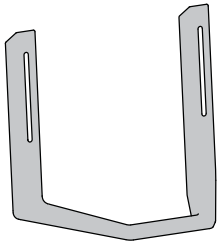

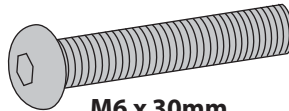

**3** 1x 

2x   
ID: 6.5mm  
OD: 12mm

2x   
M6 x 30mm

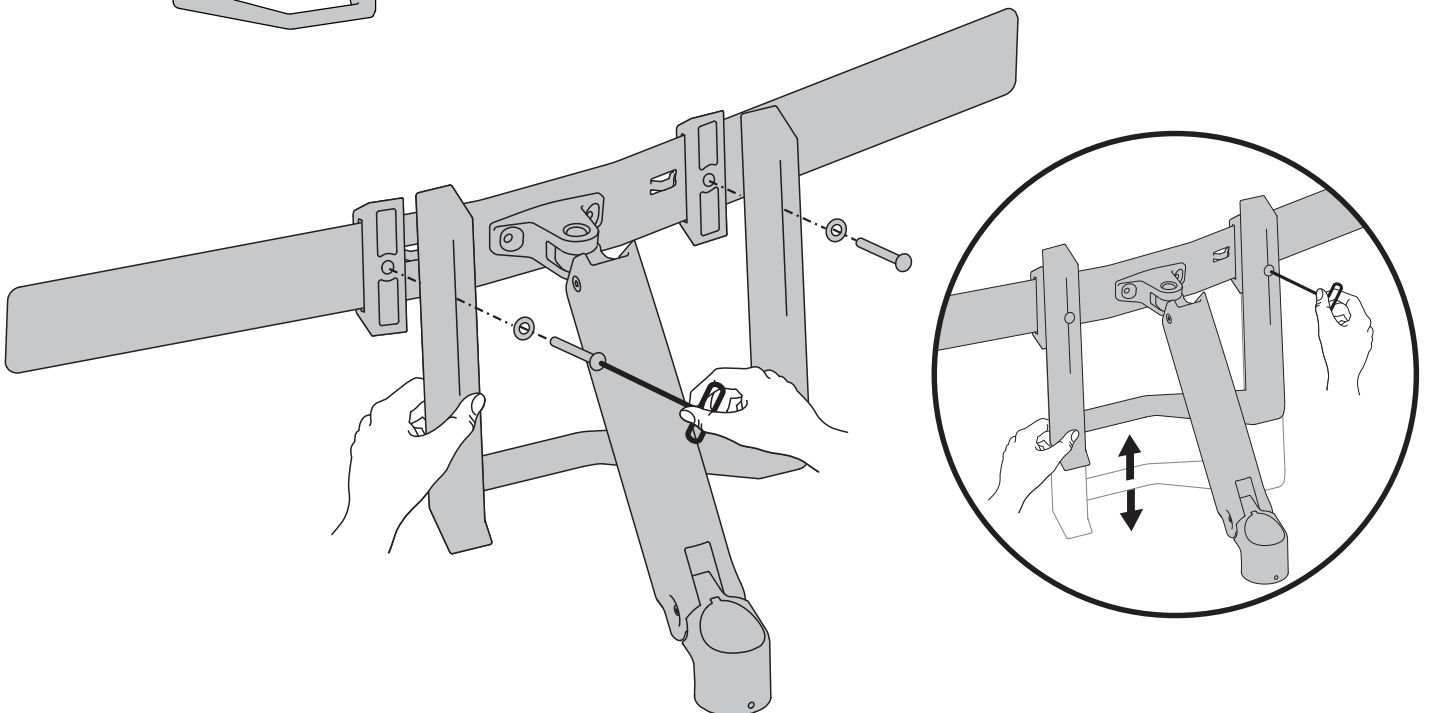
  
4 mm



3 

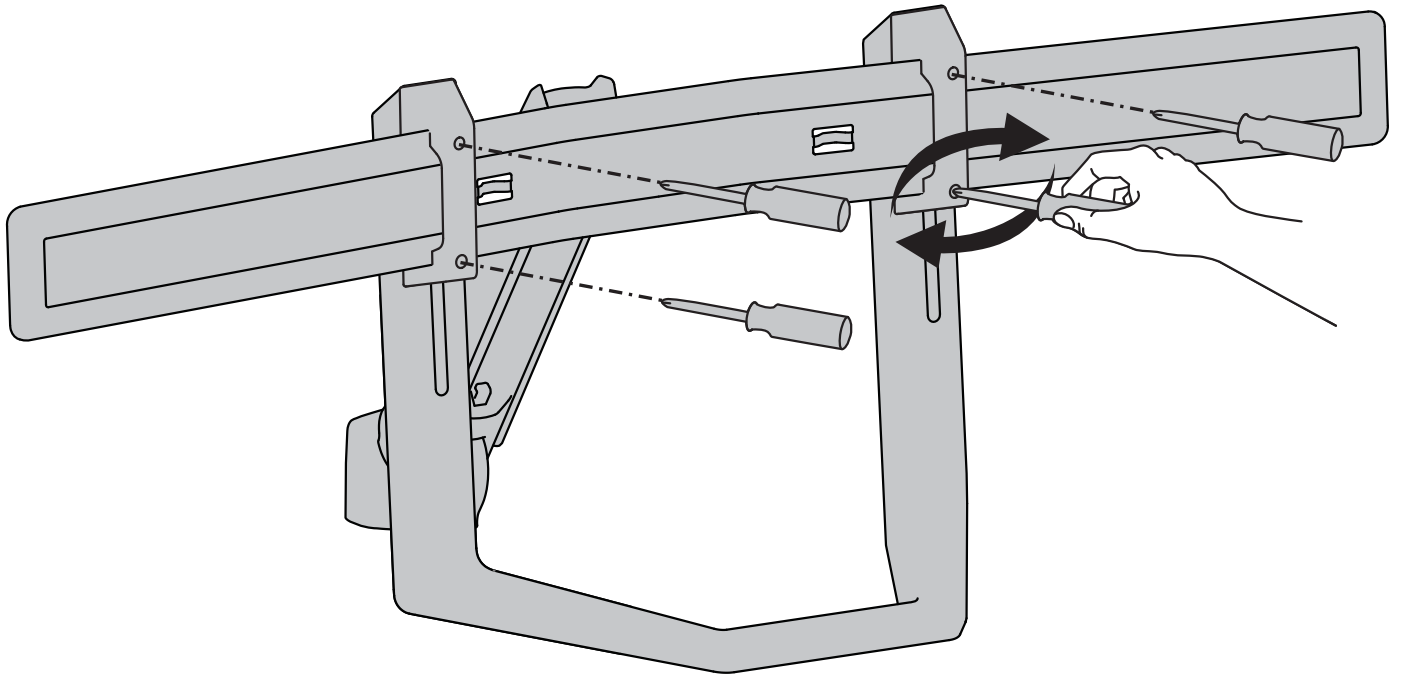

## 4 Adjustment Step

Adjust your mounting solution to handle the added weight. Adjustments should move smoothly and easily through the full range of motion and stay where you set it. If adjustments are difficult and do not stay in the desired position, follow the instructions to loosen or tighten the tension to create a smooth, easy adjustment motion. Depending on your product and the adjustment, it may take several turns to notice a difference.

## Set Your Workstation to Work For YOU!

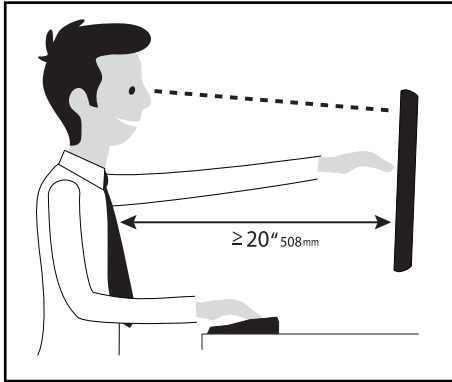

Learn more about ergonomic computer use at:  
[www.computingcomfort.org](http://www.computingcomfort.org)

- Height** Position top of screen slightly below eye level.  
Position keyboard at about elbow height with wrists flat.
- Distance** Position screen an arm's length from face—at least 20" (508mm).  
Position keyboard close enough to create a 90° angle in elbow.
- Angle** Tilt screen to eliminate glare.  
Tilt the keyboard back 10° so that your wrists remain flat.

### To Reduce Fatigue

- Breathe - Breathe deeply through your nose.
- Blink - Blink often to avoid dry eyes.
- Break • 2 to 3 minutes every 20 minutes
- 15 to 20 minutes every 2 hours.

For Warranty visit: [www.ergotron.com/warranty](http://www.ergotron.com/warranty)

For Service visit: [www.ergotron.com](http://www.ergotron.com)

For local customer care phone numbers visit: <http://contact.ergotron.com>

NOTE: When contacting customer service, reference the serial number.

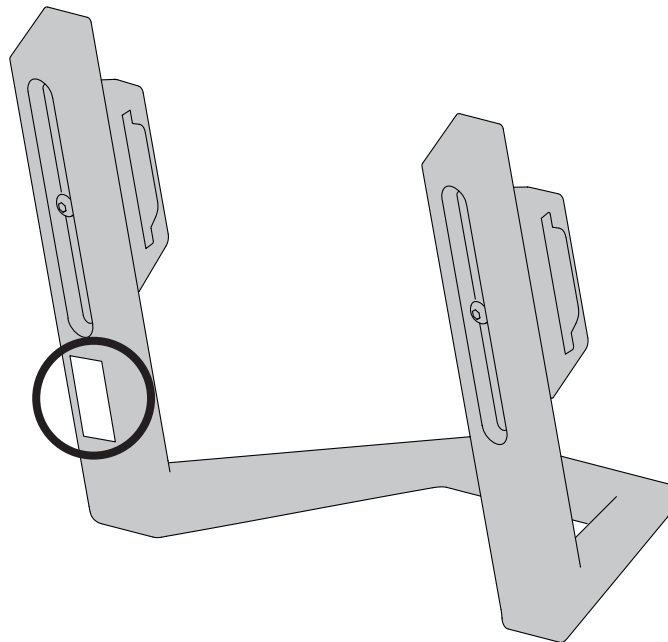

# ergotron®

[www.ergotron.com](http://www.ergotron.com) | USA: 1-800-888-8458 | Europe: +31 (0)33-45 45 600 | China: 400-120-3051 | Japan: [japansupport@ergotron.com](mailto:japansupport@ergotron.com)

© 2016 Ergotron, Inc. All rights reserved.

While Ergotron, Inc. makes every effort to provide accurate and complete information on the installation and use of its products, it will not be held liable for any editorial errors or omissions (including those made in the process of translation from English to another language), or for incidental, special or consequential damages of any nature resulting from furnishing this instruction and performance of equipment in connection with this instruction. Ergotron, Inc. reserves the right to make changes in the product design and/or product documentation without notification to its users. For the most current product information, or to know if this document is available in languages other than those herein, please contact Ergotron. No part of this publication may be reproduced, stored in a retrieval system, or transmitted in any form or by any means, electronic, mechanical, photocopying, recording or otherwise without the prior written consent of Ergotron, Inc., 1181 Trapp Road, Eagan, Minnesota, 55121, USA Patents Pending and Patented U.S. & Foreign. Ergotron is a registered trademark of Ergotron, Inc.