



Digital Projector

User Manual

Laser Projector | LH830ST / LK830ST / LW830ST

V.1.1



Warranty and Copyright information

Limited warranty

BenQ warrants this product against any defects in material and workmanship, under normal usage and storage.

Proof of purchase date will be required with any warranty claim. In the event this product is found to be defective within the warranty period, BenQ's only obligation and your exclusive remedy shall be replacement of any defective parts (labor included). To obtain warranty service, immediately notify the dealer from which you purchased the product of any defects.

IMPORTANT: The above warranty shall be void if the customer fails to operate the product in accordance with BenQ's written instructions, especially the ambient humidity must be in-between 10% and 90%, temperature in-between 0°C and 35°C, altitude lower than 4920 feet, and avoiding to operate the projector in a dusty environment. This warranty gives you specific legal rights, and you may have other rights which vary from country to country.

For other information, please visit www.BenQ.com.

Copyright

Copyright 2025 by BenQ Corporation. All rights reserved. No part of this publication may be reproduced, transmitted, transcribed, stored in a retrieval system or translated into any language or computer language, in any form or by any means, electronic, mechanical, magnetic, optical, chemical, manual or otherwise, without the prior written permission of BenQ Corporation.

Disclaimer

BenQ Corporation makes no representations or warranties, either expressed or implied, with respect to the contents hereof and specifically disclaims any warranties, merchantability or fitness for any particular purpose. Further, BenQ Corporation reserves the right to revise this publication and to make changes from time to time in the contents hereof without obligation to notify any person of such revision or changes.

*DLP, Digital Micromirror Device and DMD are trademarks of Texas Instruments. Others are copyrights of their respective companies or organizations.

Table of Contents

Warranty and Copyright information	2
Important safety instructions	4
Introduction	8
Package contents	8
Projector exterior view	10
Terminal	11
Controls and functions	12
Positioning your projector	14
Choosing a location	14
Obtaining a preferred projected image size.....	15
Mounting the projector.....	17
Adjusting the projected image.....	18
Connection	20
Operations	21
Starting up the projector	21
Using the menus	22
Securing the projector	23
Switching input signal	23
Upgrades the firmware	24
Shutting down the projector	25
Menu operation	26
Basic Menu	26
Advanced Menu	27
Controlling projector with a mobile device	52
Installing the InstaControl app on a mobile device.....	52
Connecting the BT dongle.....	52
Pairing the InstaControl app and BT dongle	53
Controlling the projector with a mobile device.....	54
Unpairing and linking to another projector.....	58
Maintenance	59
Care of the projector	59
Light Source Information	60
Troubleshooting	62
Specification	63
Projector specifications.....	63
Dimensions.....	64
Timing chart	65
RS232 command.....	68

Important safety instructions

Your projector is designed and tested to meet the latest standards for safety of information technology equipment. However, to ensure safe use of this product, it is important that you follow the instructions mentioned in this manual and marked on the product.

1. **Please read this user manual before you operate your projector.**

Save it for future reference.

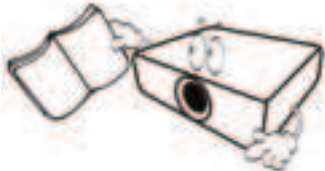

2. **Do not look straight at the projector lens during operation.**

It may harm your sight.



3. **Refer servicing to qualified service personnel.**



4. Always remove the lens cap when the projector light source is on.

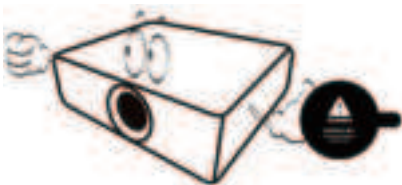

5. The light source becomes extremely hot during operation.



6. In some countries, the line voltage is NOT stable. This projector is designed to operate safely within a mains voltage between 100 to 240 volts AC, but could fail if power cuts or surges of ± 10 volts occur.

In areas where the mains voltage may fluctuate or cut out, it is recommended that you connect your projector through a power stabilizer, surge protector or uninterruptible power supply (UPS).

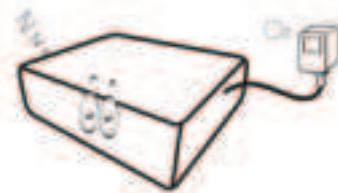

7. Do not block the projection lens with any objects when the projector is under operation as this could cause the objects to become heated and deformed or even cause a fire. To temporarily turn off the light source, press the **ECO BLANK** button.



8. Do not operate light sources beyond the rated light source life.

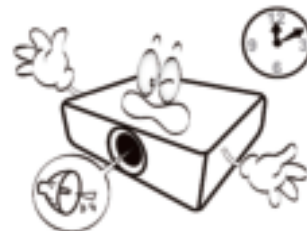

9. Do not place this product on an unstable cart, stand, or table. The product may fall, sustaining serious damage.

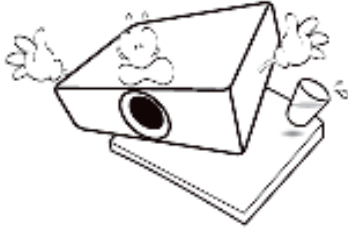

10. Do not attempt to disassemble this projector. There are dangerous high voltages inside which may cause death if you should come into contact with live parts.

Under no circumstances should you ever undo or remove any other covers. Refer servicing only to suitably qualified professional service personnel.

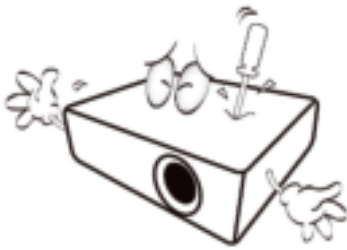

11. Do not block the ventilation holes.
- Do not place this projector on a blanket, bedding or any other soft surface.
 - Do not cover this projector with a cloth or any other item.
 - Do not place inflammables near the projector.



If the ventilation holes are seriously obstructed, overheating inside the projector may result in a fire.

12. Always place the projector on a level, horizontal surface during operation.



13. Do not stand the projector on end vertically. Doing so may cause the projector to fall over, causing injury or resulting in damage to the projector.

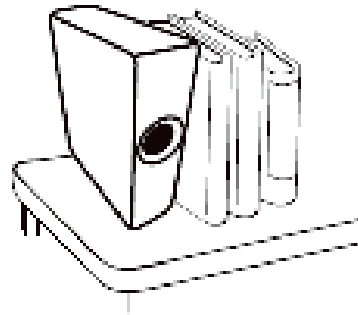

14. Do not step on the projector or place any objects upon it. Besides probable physical damage to the projector, doing so may result in accidents and possible injury.



15. When the projector is under operation, you may sense some heated air and odor from its ventilation grill. It is a normal phenomenon and not a product defect.

16. Do not place liquids near or on the projector. Liquids spilled into the projector may cause it to fail. If the projector does become wet, disconnect it from the power supply's power outlet and call BenQ to have the projector serviced.

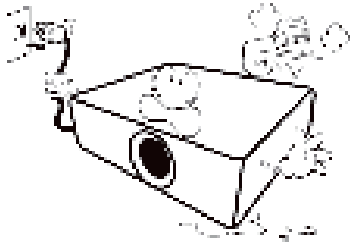

17. This product is capable of displaying inverted images for ceiling mount installation.

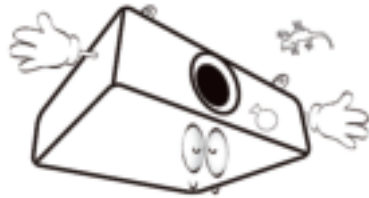

18. This apparatus must be earthed.

19. To avoid damaging the DLP chips, never aim a high-power laser beam into the projection lens.

20. Do not place this projector in any of the following environments.

Poorly ventilated or confined space can significantly increase noise levels. **Allow at least 50 cm clearance from walls and free flow of air around the projector.**

Locations where temperatures may become excessively high, such as the inside of a car with all windows rolled up. Locations where excessive humidity, dust, or cigarette smoke may contaminate optical components, shorten the projector's life span and darken the image.

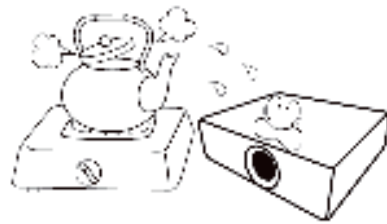

Locations near fire alarms.

Locations with an ambient temperature above 40°C/ 104°F.

Locations where the altitudes are higher than 3000 m.



NOTICE

To ensure safe use of this product, please read the user manual carefully before you operate the projector.

Risk Group 2

1. According to the classification of photobiological safety of light sources and light source systems, this product is Risk Group 2, IEC 62471-5:2015.
2. Possibly hazardous optical radiation emitted from this product.
3. Do not stare at operating light source. May be harmful to the eyes.
4. As with any bright source, do not stare into the direct beam.



The projector's light source unit uses the laser.

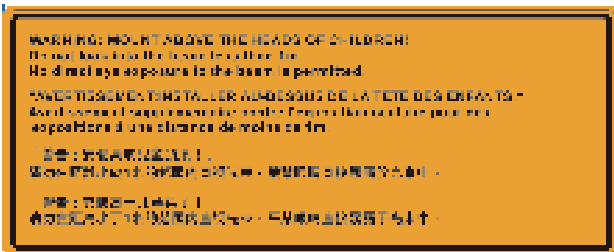

- Notice is given to supervise children and to never allow them to stare into the projector beam at any distance from the projector.

- Notice is given to use caution when using the remote control for starting the projector while in front of the projection lens.
- Notice is given to the user to avoid the use of optional aids such as binoculars or telescopes inside the beam.

Laser caution

This product belongs to CLASS 1 consumer laser product and complies with IEC 60825-1:2014, EN 60825-1:2014/A11:2021 and EN 50689:2021.



Above laser cautions are located on the bottom of this apparatus.

Caution – Use of controls or adjustments or performance of procedures other than those specified herein may result in hazardous radiation exposure.

Introduction

Package contents

Carefully unpack and verify that you have all of the items shown below. If any of these items are missing, please contact your place of purchase.

Standard accessories

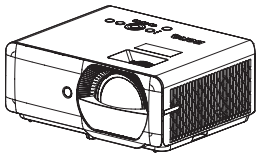

Projector

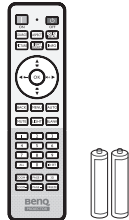

Remote controls with batteries

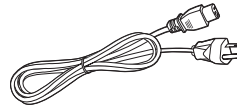

Power cord

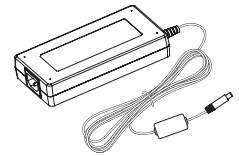

Power adapter

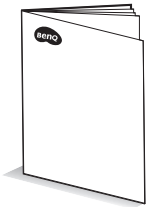

Quick Start Guide



Warranty Card



Regulatory statements



- The supplied accessories will be suitable for your region, and may differ from those illustrated.
- * The warranty card is only supplied in some specific regions. Please consult your dealer for detailed information.

Optional accessories

- Filter
- BT dongle
- Universal wall mount

Installing the filter (purchased separately)

For optional filter module assembly:

1. Put filters (right + back) into the L cover.

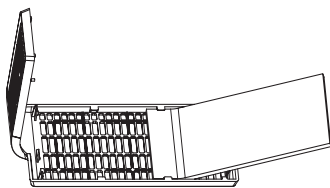

Right side filter installation

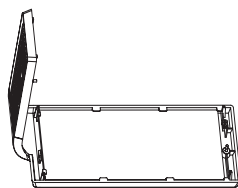

Right side filter installation is complete

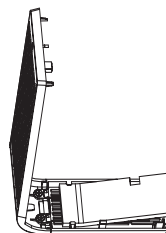

Back side filter installation

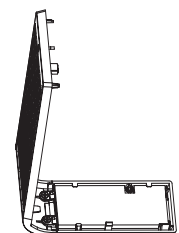

Back side filter installation is complete

2. Power off the projector (without disconnecting the power cord) and keep it on standby.
3. Use the provided screws to fix the filter module onto projector.

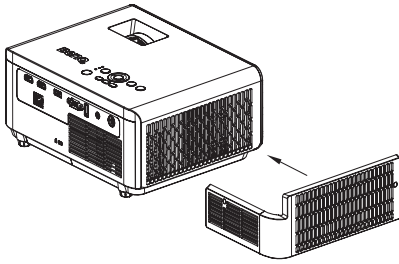

Align the filter module with the projector

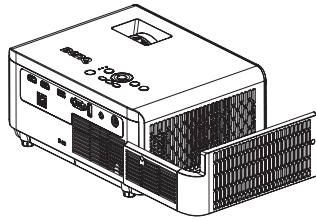

Right side filter installation is complete

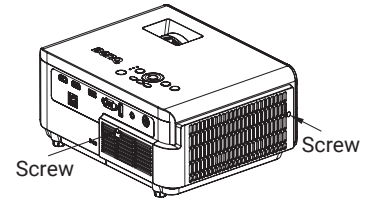

Back side filter installation



If the power cord of the projector is disconnected while assembling the filter module, please reset timer manually by RS232 command.

Replacing the remote control batteries

1. Press and slide off the battery cover, as illustrated.
2. Remove the old batteries (if applicable) and install two AAA batteries. Make sure that the positive and negative ends are positioned correctly, as illustrated.
3. Slide the battery cover in until it clicks into place.

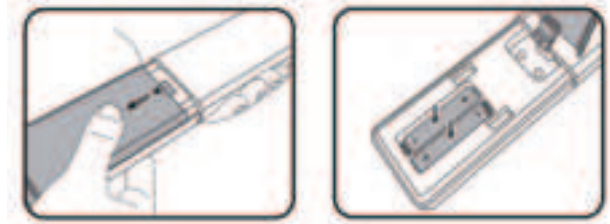

- Avoid leaving the remote control and batteries in an excessively hot or humid environment like the kitchen, bathroom, sauna, sunroom or in a closed car.
- Replace only with the same or equivalent type recommended by the battery manufacturer.
- Dispose of the used batteries according to the manufacturer's instructions and local environment regulations for your region.
- Do not throw the battery into a fire as this may cause it to explode.
- If the batteries are dead or if you will not be using the remote control for an extended period of time, remove the batteries to avoid damage to the remote control from possible battery leakage.
- Risk of explosion if the battery is replaced by an incorrect type.
- Disposal of a battery into fire or a hot oven, or mechanically crushing or cutting of a battery, that can result in an explosion.
- Leaving a battery in an extremely high temperature surrounding environment that can result in an explosion or the leakage of flammable liquid or gas.
- A battery subjected to extremely low air pressure that may result in an explosion or the leakage of flammable liquid or gas.

Projector exterior view

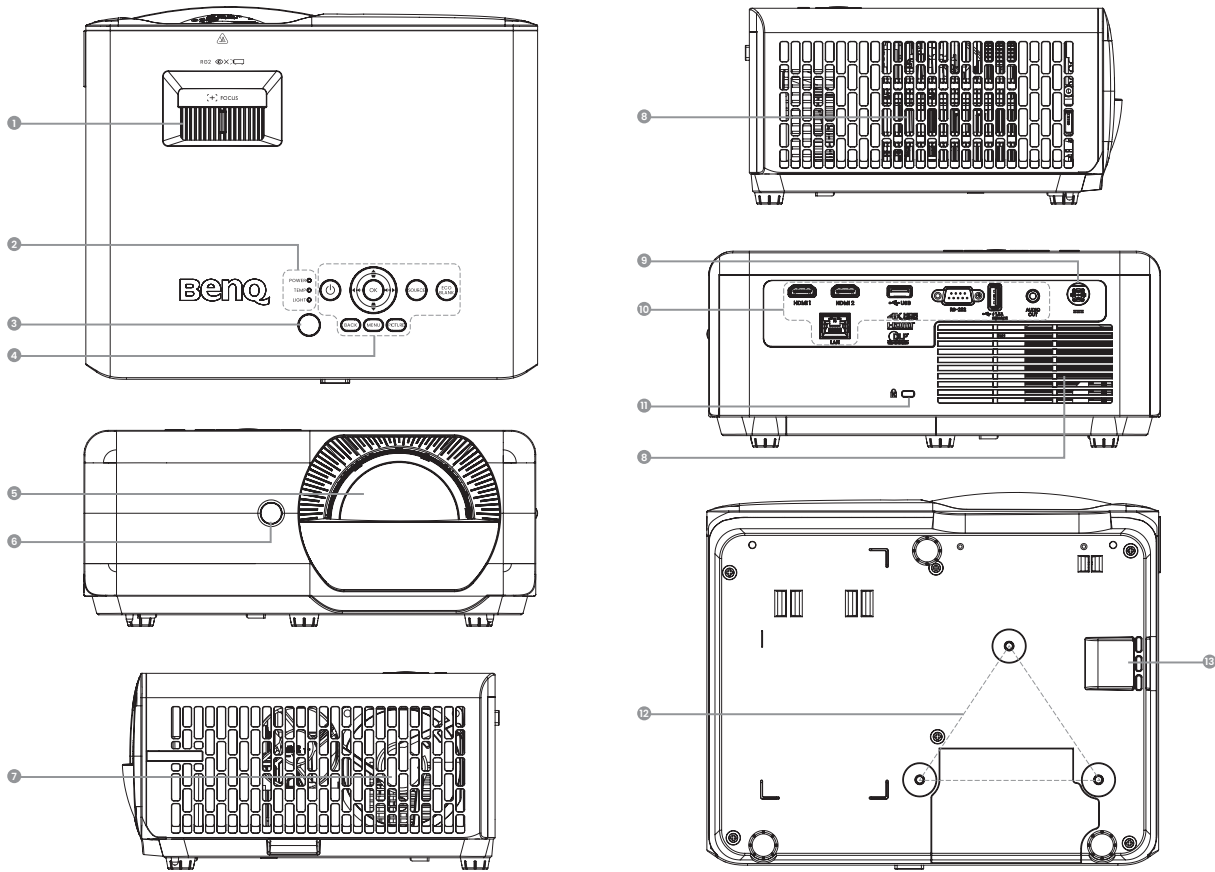

- | | |
|---|--|
| <ul style="list-style-type: none"> 1. Focus ring 2. LED Indicators 3. IR remote sensor 4. External control panel
Refer to "Controls and functions" on page 12. 5. Projection lens 6. IR remote sensor | <ul style="list-style-type: none"> 7. Vent (air exhaust) 8. Vent (air inlet) 9. DC-IN port 10. Connector panel
Refer to "Terminal" on page 11. 11. Anti-theft security bar 12. Ceiling mount holes 13. Security Bar |
|---|--|

Terminal

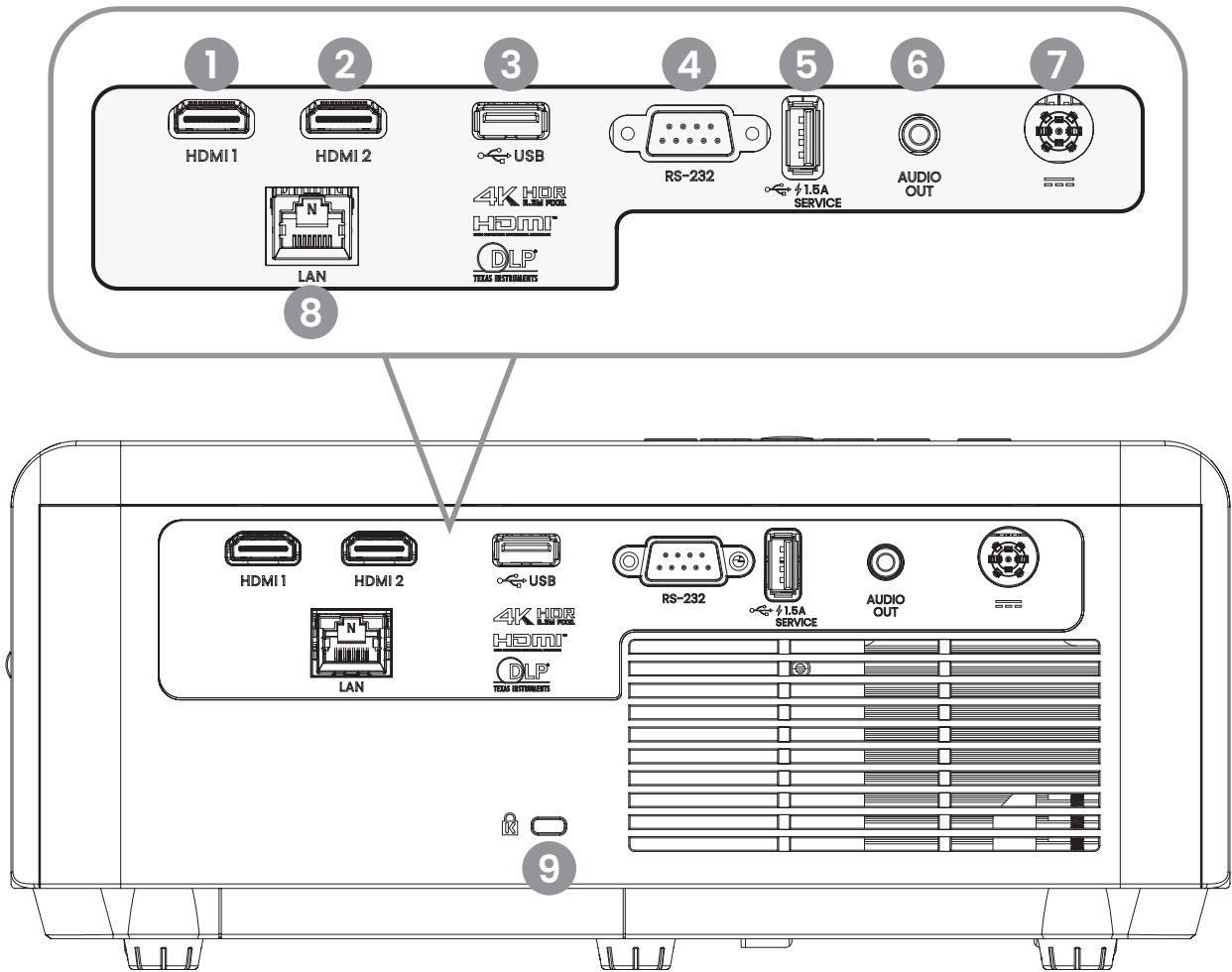

- | | |
|--|--|
| 1. HDMI input connector (2.0b, HDCP 2.2) | 6. Audio output port |
| 2. HDMI input connector (2.0b, HDCP 2.2) | 7. DC-IN port |
| 3. USB 3.0 Type-A port | 8. RJ-45 LAN input connector (Direct Connect) |
| 4. RS232 control port | 9. Kensington lock port (anti-theft lock slot) |
| 5. SERVICE (Type A, 5V 1.5A) for FW update | |



• Only LK830ST model supports **4K HDR** 6.3M PIXEL.

Controls and functions

Projector & Remote control



All the key presses described in this document are available on the remote control or projector.

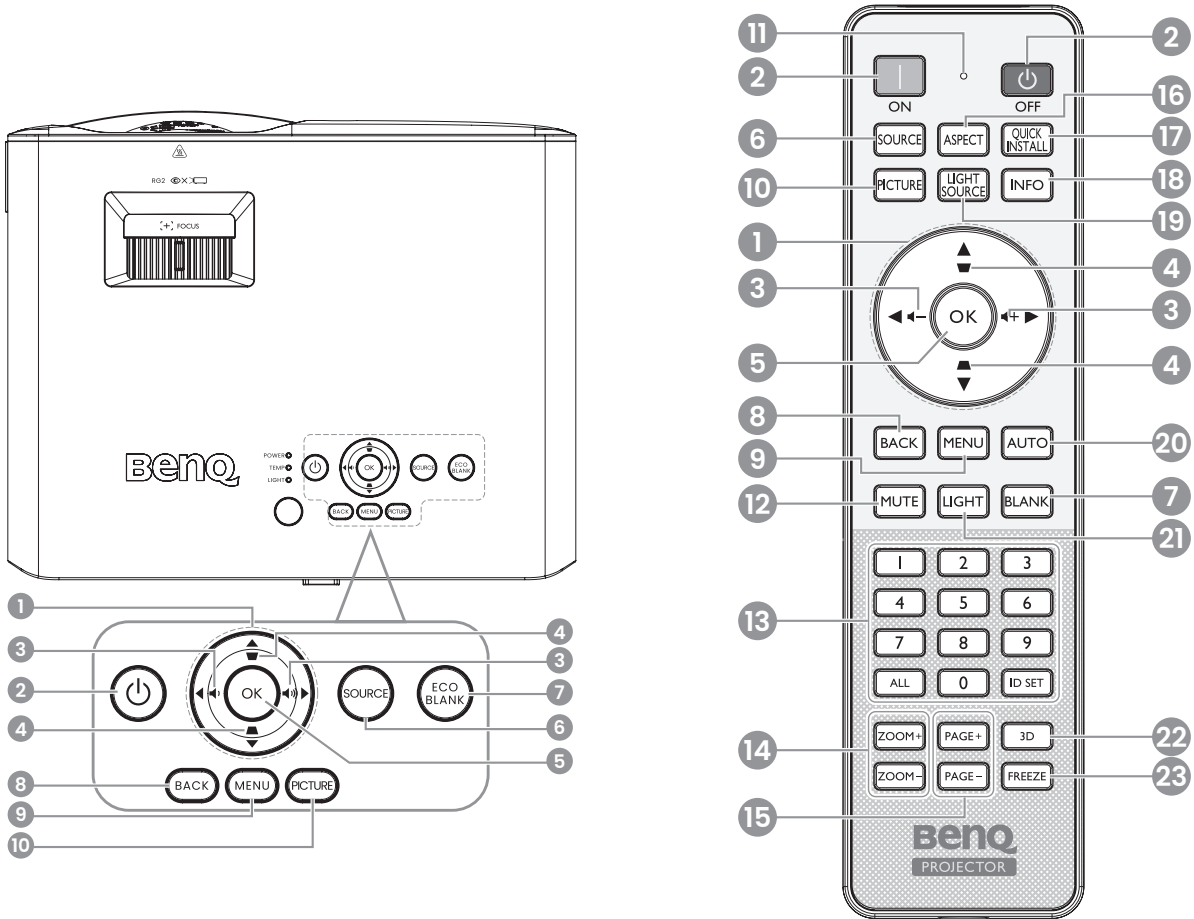

1. Arrow keys

When the On-Screen Display (OSD) menu is activated, these keys are used as 4 directional arrows to select the desired menu items and to make adjustments.

2. POWER

Toggles the projector between standby mode and on.

3. VOLUME

Adjust volume.

4. KEYSTONE

Adjust projector keystone.

5. OK

Confirms the selected On-Screen Display (OSD) menu item.

6. SOURCE

A source selection bar appears.

7. ECO BLANK

Used to hide the screen image.

8. BACK

Goes back to previous OSD menu, exits and saves menu settings.

9. MENU

Turns on/off the On-Screen Display (OSD) menu.

10. PICTURE MODE

Displays the picture mode menu.

11. ID LED

ID setting indicator.

12. MUTE

Mutes audio.

13. ID CODE KEYS

Projector ID code keys.

14. ZOOM +/-

Increases (+)/decreases (-) the size of the projected image.

15. PAGE+/PAGE-

Moves page up (+) or page down (-).

16. ASPECT

Selects the display aspect ratio.

17. QUICK INSTALL

Opens quick setup.

18. INFO

Displays projector information.

19. LIGHT SOURCE

Selects a suitable light power from among the provided modes.

20. AUTO

Not supported.

21. LIGHT

Turns on/off RC key backlight.

22. 3D

Displays the 3D menu.

23. FREEZE

Freezes/unfreezes the projected image.

Remote control effective range

The remote control must be held at an angle within 30 degrees perpendicular to the projector's IR remote control sensor(s) to function correctly. The distance between the remote control and the sensor(s) should not exceed 8 meters (~ 26 feet).

Make sure that there are no obstacles between the remote control and the IR sensor(s) on the projector that might obstruct the infra-red beam.

- Operating the projector from the top side

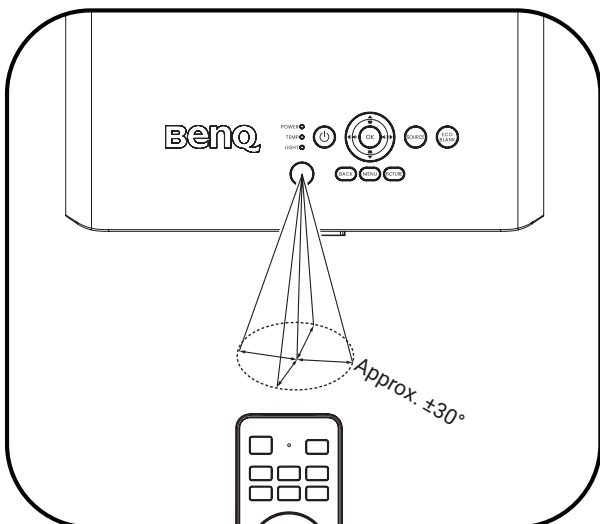

- Operating the projector from the front side

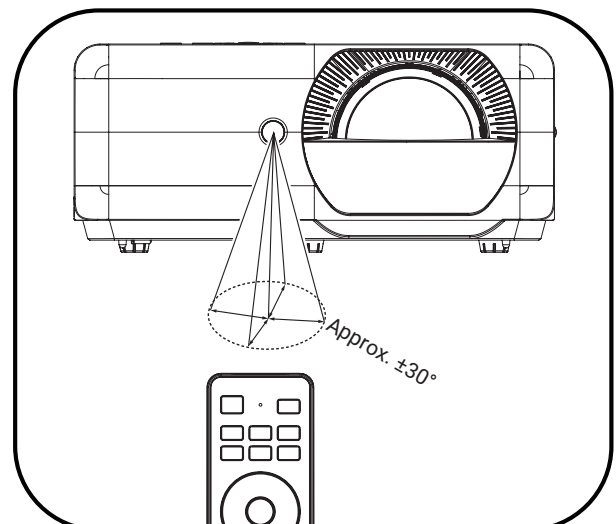

Positioning your projector

Choosing a location

Before choosing an installation location for your projector, take the following factors into consideration:

- Size and position of your screen
- Electrical outlet location
- Location and distance between the projector and the rest of your equipment

The projected image size and vertical offset depend on how far you place the projector, and the zoom setting you choose. See "[Projection screen size](#)" on page 15 for more information. It can help you decide exact distance and height of your projector.

You can install your projector in the following ways.

1. Front

Select this location with the projector placed on the table in front of the screen. This is the most common way to position the projector for quick setup and portability.

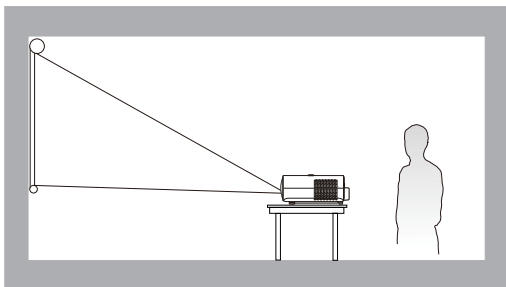

2. Front Ceiling

Select this location with the projector suspended upside-down from the ceiling in front of the screen. Purchase the BenQ Projector Ceiling Mount Kit from your dealer to mount your projector on the ceiling.

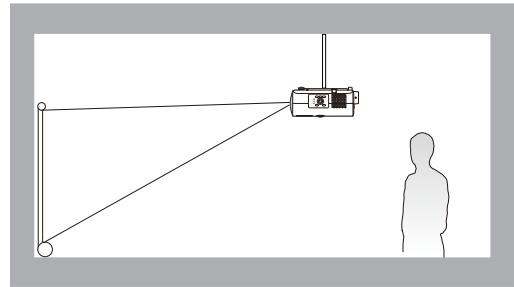

3. Rear

Select this location with the projector placed on the table behind the screen. Note that a special rear projection screen is required.

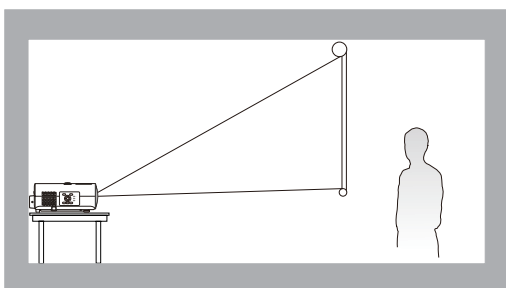

4. Rear Ceiling

Select this location with the projector suspended upside-down from the ceiling behind the screen. Note that a special rear projection screen and the BenQ Projector Ceiling Mount Kit are required for this installation location.

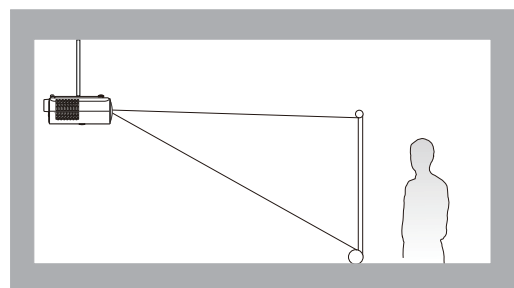

After turning on the projector, go to **Advanced** menu - **Installation** > **Projector Position**, press **OK** and press **◀/▶** to select a setting.

Obtaining a preferred projected image size

The distance from the projector lens to the screen, the focus setting, and the video format each factors in the projected image size.

Projection screen size

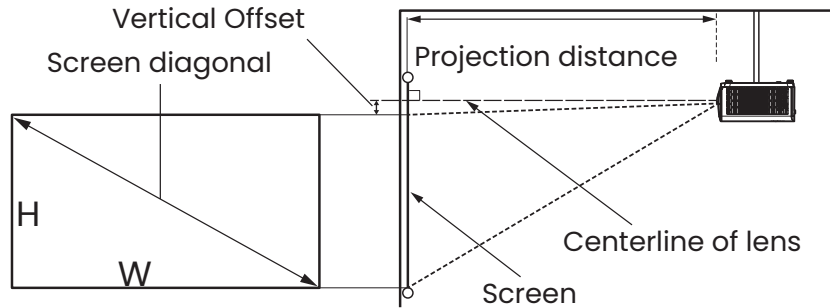

- For LH830ST/LK830ST, the screen aspect ratio is 16:9 and the projected picture is in a 16:9 aspect ratio.
- For LW830ST, the screen aspect ratio is 16:10 and the projected picture is in a 16:10 aspect ratio.
- The Projection performance will differ based on actual projection size and ambient light.

Screen Size				Distance from screen (mm)	Vertical offset (mm)	
Diagonal		H (mm)	W (mm)		LH830ST	LK830ST
Inch	mm					
70	1778	872	1550	769	139	122
80	2032	996	1771	878	159	139
90	2286	1121	1992	988	179	157
100	2540	1245	2214	1098	199	174
110	2794	1370	2435	1208	219	192
120	3048	1494	2657	1318	239	209
130	3302	1619	2878	1427	259	227
140	3556	1743	3099	1537	279	244
150	3810	1868	3321	1647	299	262
160	4064	1992	3542	1757	319	279
170	4318	2117	3763	1867	339	296
180	4572	2241	3985	1976	359	314
190	4826	2366	4206	2086	379	331
200	5080	2491	4428	2196	398	349
210	5334	2615	4649	2306	418	366
220	5588	2740	4870	2416	438	384
230	5842	2864	5092	2526	458	401
240	6096	2989	5313	2635	478	418
250	6340	3113	5535	2745	498	436
260	6604	3238	5756	2855	518	453
270	6858	3362	5977	2965	538	471
280	7112	3487	6199	3075	558	488
290	7366	3611	6420	3184	578	506
300	7620	3736	6641	3294	598	523

Screen Size				Distance from screen (mm)	Vertical offset (mm)
Diagonal		H (mm)	W (mm)		LW830ST
Inch	mm				
70	1778	942	1508	786	117
80	2032	1077	1723	898	134
90	2286	1212	1939	1010	150
100	2540	1346	2154	1122	167
110	2794	1481	2369	1234	184
120	3048	1615	2585	1347	200
130	3302	1750	2800	1459	217
140	3556	1885	3015	1571	234
150	3810	2019	3231	1683	250
160	4064	2154	3446	1796	267
170	4318	2289	3662	1908	284
180	4572	2423	3877	2020	300
190	4826	2558	4092	2132	317
200	5080	2692	4308	2244	334
210	5334	2827	4523	2357	351
220	5588	2962	4739	2469	367
230	5842	3096	4954	2581	384
240	6096	3231	5169	2693	401
250	6350	3365	5385	2805	417
260	6604	3500	5600	2918	434
270	6858	3635	5816	3030	451
280	7112	3769	6031	3142	467
290	7366	3904	6246	3254	484
300	7620	4039	6462	3367	501



- All measurements are approximate and may vary from the actual sizes.
- BenQ recommends that if you intend to permanently install the projector, you should physically test the projection size and distance using the actual projector on site before you permanently install it, so as to make allowance for this projector's optical characteristics. This will help you determine the exact mounting position so that it best suits your installation location.

Mounting the projector

If you intend to mount your projector, we strongly recommend that you use a proper fitting BenQ projector mounting kit and that you ensure it is securely and safely installed.

If you use a non-BenQ brand projector mounting kit, there is a safety risk that the projector may fall down due to an improper attachment through the use of the wrong gauge or length screws.

Before mounting the projector

- Purchase a BenQ projector mounting kit from the place you purchased your BenQ projector.
- BenQ recommends that you also use a security cable to secure both the base of the mounting bracket and the security bar on the projector. This will perform the secondary role of restraining the projector should its attachment to the mounting bracket become loose.
- Ask your dealer to install the projector for you. Installing the projector on your own may cause it to fall and result in injury.
- Take necessary procedures to prevent the projector from falling off such as during an earthquake.
- The warranty doesn't cover any product damage caused by mounting the projector with a non-BenQ brand projector mounting kit.
- Consider the surrounding temperature where the projector is ceiling mounted. If a heater is used, the temperature around the ceiling may be higher than expected.
- Read the user manual for the mounting kit about the range of torque. Tightening with torque exceeding the recommended range may cause damage to the projector and subsequently falling off.
- Make sure the power outlet is at an accessible height so that you can easily shut down the projector.

Ceiling/Wall mount installation diagram

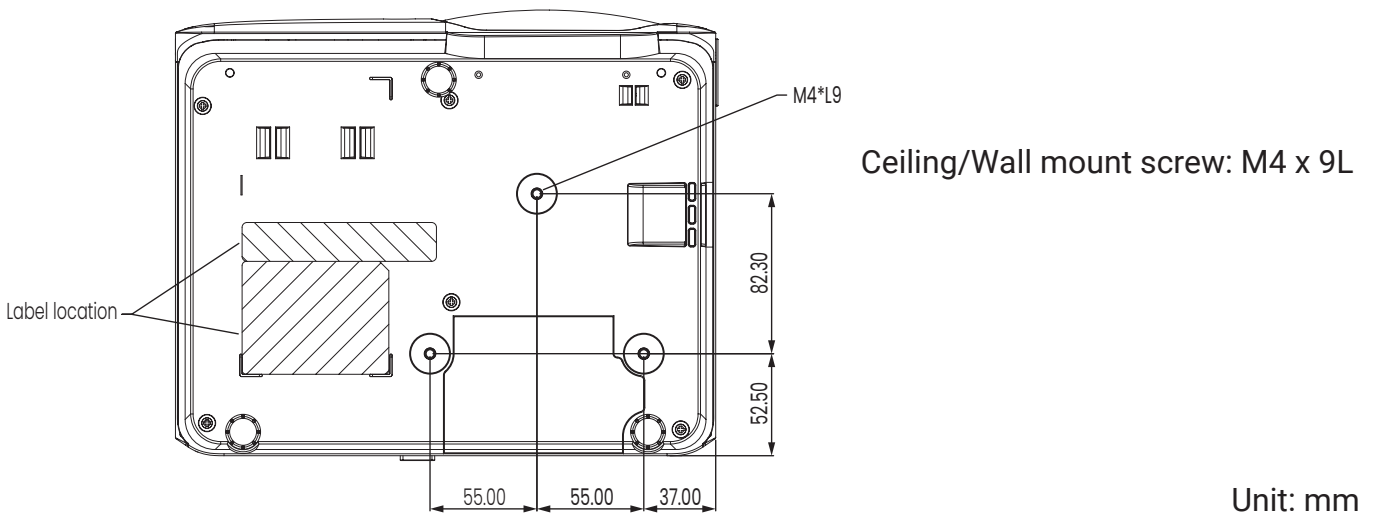

Adjusting the projected image

Adjusting the projection angle

If the projector is not placed on a flat surface or the screen and the projector are not perpendicular to each other, the projected image becomes trapezoidal.

You can screw the adjuster feet to fine-tune the horizontal angle.

To retract the feet, screw the adjuster feet in a reverse direction.

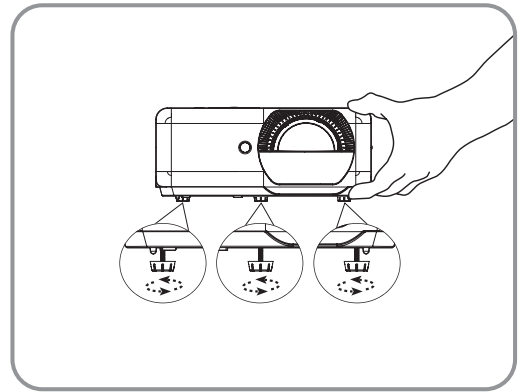

• Do not look into the lens while the light source is on. The strong light from the light source may cause damage to your eyes.

Fine-tuning the image size and clarity

Use the Focus function in the Lens Control and adjust with the arrow keys.

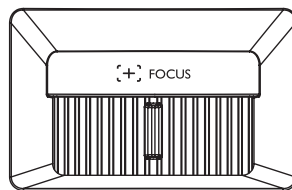

Adjust Focus

* Adjusts the clarity of the image

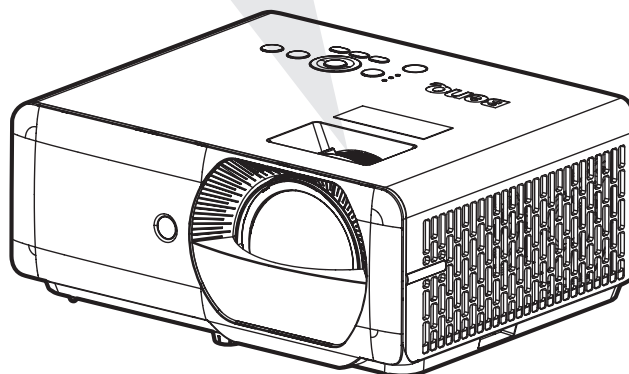

Correcting keystone

Keystoning refers to the situation where the projected image becomes a trapezoid due to angled projection.

To correct the distorted image:

1. Display the **2D Keystone** correction page from the following menus.
 - The setup wizard during the projector initial setup.
 - The **Basic** menu system.
 - The **Installation** menu of the **Advanced** menu system.

2. After the **2D Keystone** correction page appears:

- To correct keystone at the top of the image, use ▼.
- To correct keystone at the bottom of the image, use ▲.
- To correct keystone at the right side of the image, use ◀.
- To correct keystone at the left side of the image, use ▶.
- To reset the keystone values, please press **BACK** for 2 seconds.
- To automatically correct the vertical sides of the distorted image, press **OK** for 2 seconds.

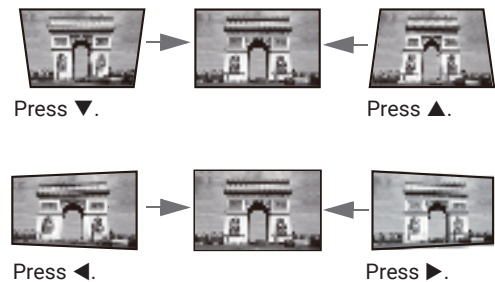

3. When done, press **BACK** to save the changes and exit.

Connection

When connecting a signal source to the projector, be sure to:

1. Turn all equipment off before making any connections.
2. Use the correct signal cables for each source.
3. Make sure the cables are firmly inserted.

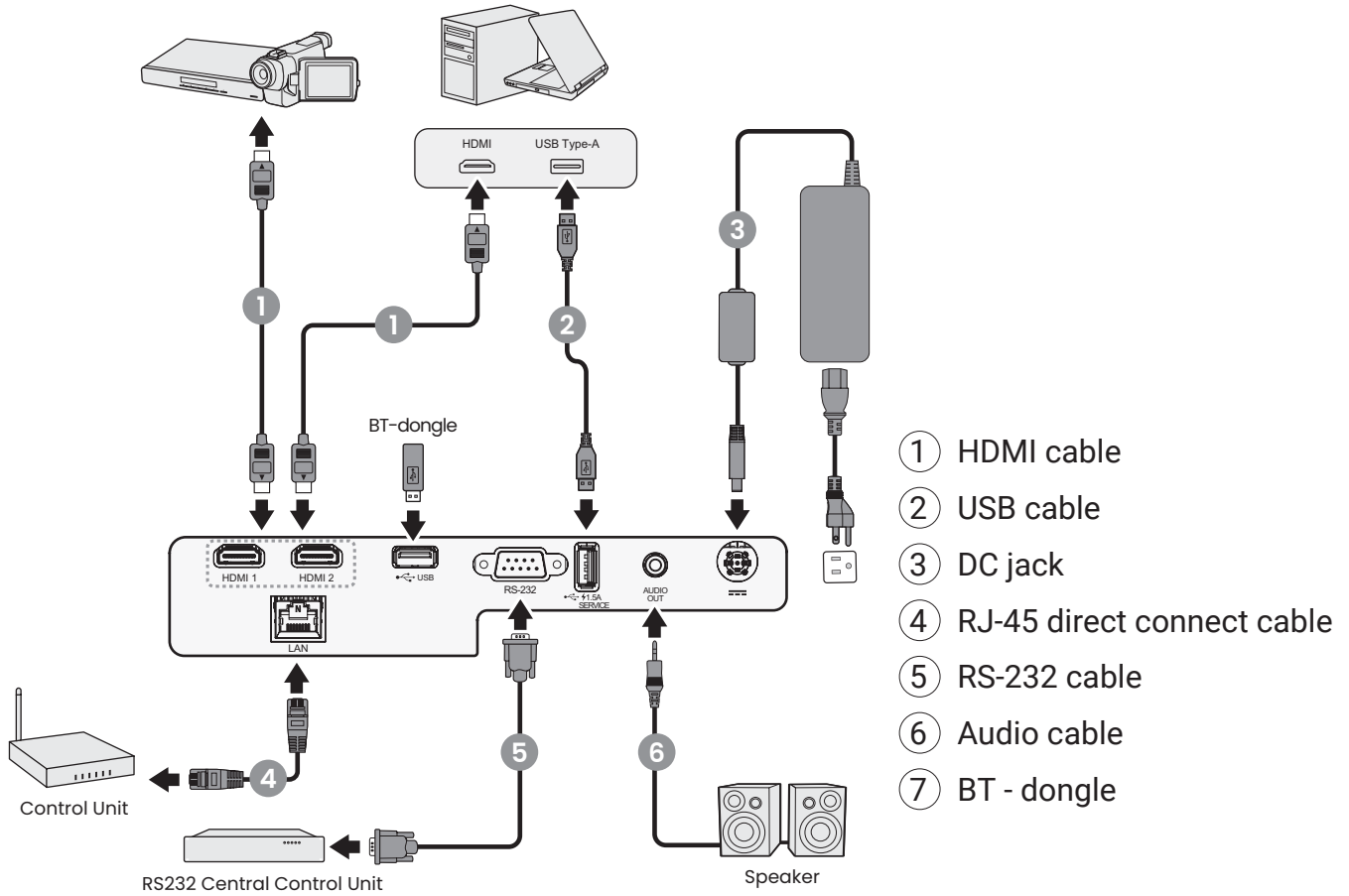

- BT-dongle is sold separately
- Please contact your local support team for assistance with product availability.
- In the connections above, some cables may not be included with the projector (see ["Package contents" on page 8](#)). They are commercially available from electronics stores.
- The connection illustrations are for reference only. The rear connecting jacks available on the projector vary with each projector model.
- Many notebooks do not turn on their external video ports when connected to a projector. Usually a key combo like FN + function key with a monitor symbol turns the external display on/off. Press FN and the labeled function key simultaneously. Refer to your notebook's documentation to find your notebook's key combination.
- If the selected video image is not displayed after the projector is turned on and the correct video source has been selected, check that the video source device is turned on and operating correctly. Also check that the signal cables have been connected correctly.

Download APP to Controlling projector with a mobile device with BT-dongle

- Search for the InstaControl app from Google Play Store (Android) or App Store (iOS).



- For user in China, scan below QR code:



Operations

Starting up the projector

1. Plug the power cord. Turn on the power outlet switch (where fitted). The power indicator on the projector lights orange after power has been applied.
2. Press the power button on the projector or remote control to start the projector. The power indicator flashes green and stays green when the projector is on. The start up procedure takes about 20 seconds. In the later stage of starting up, a start-up logo is projected.
3. If this is the first time you turn on the projector, the setup wizard appears to guide you through setting up the projector. If you have already done this, skip this step and move on to the next step.
 - Use the arrow keys on the projector or remote control to move through the menu items.
 - Use OK to confirm the selected menu item.

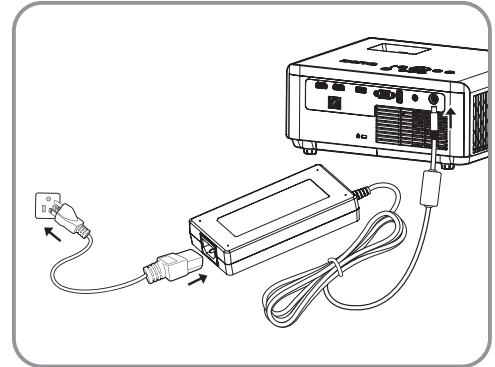

Specify OSD Language.



4. Switch all of the connected equipment on.
5. The projector will search for input signals. The current input signal being scanned appears. If the projector does not detect a valid signal, the message "No Signal" will appear until an input signal is found.

You can also press SOURCE to select your desired input signal. Refer to ["Switching input signal" on page 23](#).



• Please use the original accessories (e.g. power cord) to avoid possible dangers such as electric shock and fire.



• The Setup Wizard screenshots are for reference only and may differ from the actual design.

• If the frequency/resolution of the input signal exceeds the projector's operating range, the projection will not display the picture. Please change to an input signal which is compatible with the projector's resolution or set the input signal to a lower setting. Refer to ["Timing chart" on page 65](#).

• If no signal is detected for 3 minutes, the projector automatically enters the ECO BLANK mode.

Using the menus

The projector is equipped with 2 types of On-Screen Display (OSD) menus for making various adjustments and settings. The **Basic** OSD menu provides primary menu functions while the **Advanced** OSD menu provides full menu functions.

To access the OSD menu, press **MENU** on the projector or remote control.

- Use the arrow keys (**▲/▼/◀/▶**) on the projector or remote control to move through the menu items.
- Use **OK** on the projector or remote control to confirm the selected menu item.

The first time you use the projector (after finishing the initial setup), press **MENU**, and the **Basic** OSD menu will be displayed.

If you intend to switch from the **Basic** OSD menu to the **Advanced** OSD menu:

1. Go to **Menu Type** and press **OK**.
2. Use **▲/▼** to select **Advanced**, then press **OK**. Your projector will switch to the **Advanced** OSD menu.

Likewise, when you wish to switch from the **Advanced** OSD menu to the **Basic** OSD menu, follow the instructions below:

1. Go to **System > Menu Settings > Menu Type**, and then press **OK**.
2. Use **▲/▼** to select **Basic**, then press **OK**. Your projector will switch to the **Basic** OSD menu.

Overview of the **Basic** OSD menu.

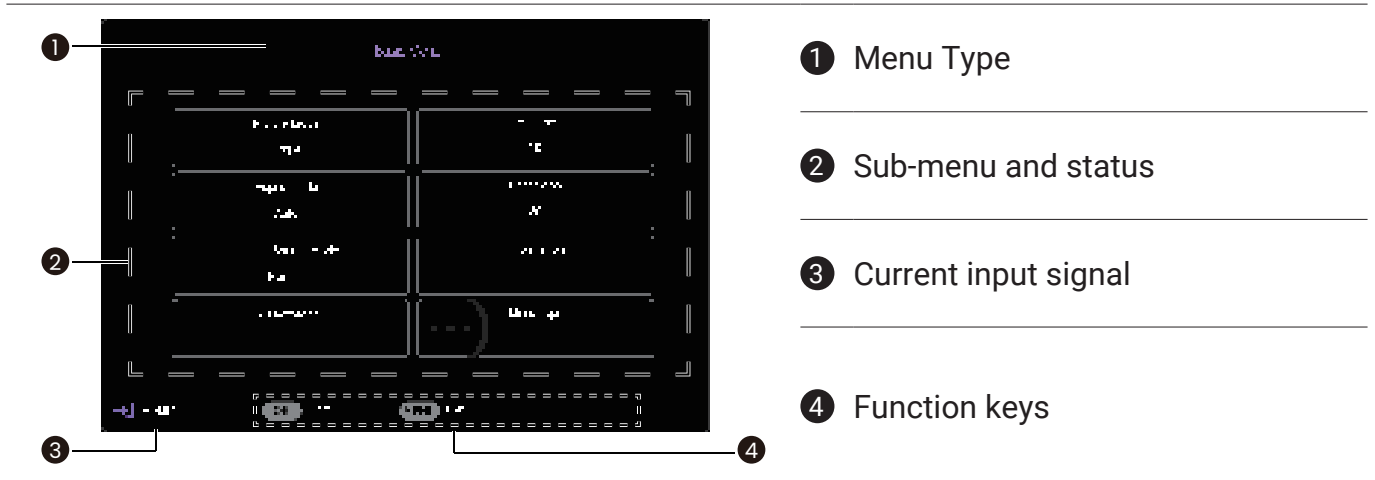

Overview of the **Advanced** OSD menu.



- 1 Main menu
- 2 Current input signal
- 3 Sub-menu and status
- 4 Function keys



The OSD screenshots are for reference only, and may differ from the actual design.

Securing the projector

The projector has to be installed in a safe place to prevent theft. Otherwise, purchase a security cable to secure the projector. A security bar is located on the bottom side of the projector. See item 13 on [page 10](#) and [page 11](#). Insert a security cable to the opening of the security bar and secure it to a nearby fixture or heavy furniture.

Switching input signal

The projector can be connected to multiple devices at the same time. However, it can only display one full screen at a time. When starting up, the projector automatically searches for the available signals.

To manually select the source:

1. Press **SOURCE**. A source selection bar appears.
2. Press **▲/▼** until your desired signal is selected and press **OK**.

Once detected, the picture from the selected source will appear. If there is multiple equipment connected to the projector, repeat steps 1-2 to search for another signal.



- The brightness level of the projected image will change accordingly when you switch between different input signals.
- For best display picture results, you should select and use an input signal which outputs at the projector's native resolution. Any other resolutions will be scaled by the projector depending upon the "aspect ratio" setting, which may cause some image distortion or loss of picture clarity. See "[Aspect Ratio](#)" on [page 35](#).

Upgrades the firmware



To secure the process, please notice the followings while performing the firmware upgrade.

1. Not to unplug the RJ45 LAN cable.
2. Not to unplug the power cord.
3. Not to operate OSD menu.

1. Go to **System > Update Firmware OTA*** menu. Then, adjust **Update Firmware OTA to On**.

Note: For LW830ST, this item will be "Device firmware auto update"

If there is a newer version of firmware available on QOTA server, a pop-up Notice (as below) is displayed on the screen while the user is turning off the projector.



2. Select **Yes** to start the automatic upgrade process. Projector will check and download the latest firmware from the QOTA server. The upgrade order is LAN, MCU, and DDP. After the upgrade procedure is complete, the projector will automatically turn off or remain operating if only LAN firmware needed an upgrade. If the user selects **No**, then the projector will turn off without upgrading firmware.

3. The projector will pop-up a Notice to inform the user about the firmware upgrade status when the user turns on the projector next time. Select **OKAY** to close the Notice.

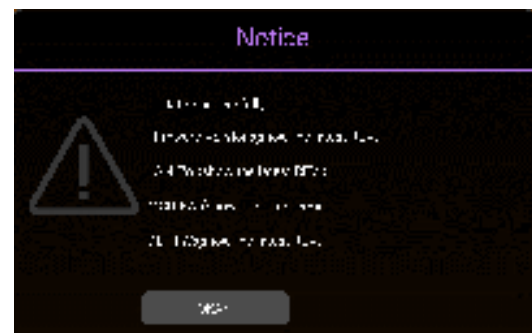
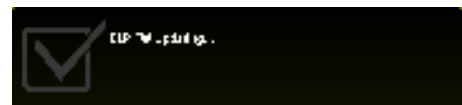
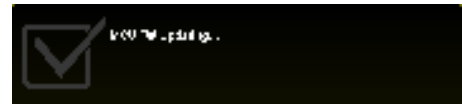
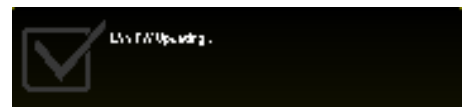

Shutting down the projector

1. Press POWER and a confirmation message will display prompting you. If you don't respond in a few seconds, the message will disappear.
2. Press the power button again. The power indicator flashes orange, the projection light source shuts down, and the fans will continue to run for approximately 10 seconds to cool down the projector.
3. Once the cooling process finishes, the power indicator becomes a steady orange and the fans stop. Disconnect the power cord from the power outlet.

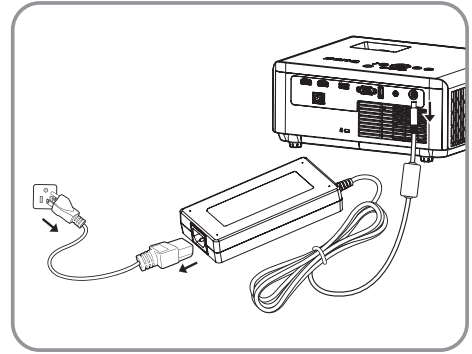

To protect the light source, the projector will not respond to any commands during the cooling process.

Menu operation

Please note that the on-screen display (OSD) menus vary according to the signal type selected and the projector model you are using. The menu items are available when the projector detects at least one valid signal. If there is no equipment connected to the projector or no signal detected, limited menu items are accessible.

Basic Menu

Structure

Menu		Options
Left - 1	Picture Mode	Bright / Simulation / sRGB / Presentation / Vivid / (3D) / (HDR10) / (HLG) / User 1 / User 2
Left - 2	Aspect Ratio	Auto / Real / 4:3 / 16:9 / 16:10
Left - 3	Light Source Mode	Normal / ECO / SmartEco / Custom
Left - 4	2D Keystone	H: -30 – +30
		V: -30 – +30
Right - 1	Volume	0 – 20
Right - 2	Brightness	0 – 100
Right - 3	Information	Native Resolution (e.g. 1080p 1920x1080)
		Detected Resolution (e.g. 1920x1080 60Hz)
		Source (e.g. HDMI-1)
		Picture Mode
		Light Source Mode
		3D Format
		Color System (RGB or YUV) (e.g. YUV444-16bit-BT2020)
		Dynamic Range (e.g. HDR10 xxxxxnits)
		Light Source Usage Time
		Projector ID (e.g. 00 – 99)
Right - 4	Menu Type	Firmware Version
		Service Code
		Basic / Advanced

Advanced Menu

1. Main menu: **Picture**

Structure

Menu	Options	
Picture Mode	Bright / Simulation / sRGB / Presentation / Vivid / (3D) / (HDR10) / (HLG) / User 1 / User 2	
User Management	Load Settings From	sRGB / Simulation / Presentation / Vivid
	Rename User Mode	
Brightness	0 – 100	
Contrast	0 – 100	
Sharpness	0 – 31 (LH830ST / LW830ST) 0 – 15 (LK830ST)	
	Gamma Selection	1.8 / 2.0 / 2.1 / 2.2 / 2.3 / 2.4 / 2.5 / 2.6 / BenQ / BenQ 2
	Color Temperature Tuning	R Gain / G Gain / B Gain 0 – 200
		R Offset / G Offset / B Offset 0 – 511
Advanced Color Settings	Color Management	R / G / B / C / M / Y Primary Color / Hue / Saturation / Gain
		W Primary Color / R Gain / G Gain / B Gain
	Reset	Reset / Cancel
	Brilliant Color	Off / On
Light Source Mode	Normal / ECO / SmartEco / Custom	
Custom Brightness	30% – 100%	
HDR Brightness	-2 / -1 / 0 / 1 / 2	
Noise Reduction	0 – 15	
Reset Current Picture Mode	Reset / Cancel	

Function descriptions

Menu	Descriptions
Picture Mode	<p>The projector is preset with several predefined picture modes so that you can choose one to suit your operating environment and input signal picture type.</p> <ul style="list-style-type: none">• Bright Maximizes the brightness of the projected image. This mode is suitable for environments where extra-high brightness is required, such as using the projector in well lit rooms.• Simulation Is designed for entertainment content; it delivers vibrant and brilliant color performance, making the visuals captivating and eye-catching. Ideal for entertainment usage.• sRGB Maximizes the purity of RGB colors to provide true-to-life images regardless of brightness and properly calibrated camera, and for viewing PC graphic and drawings setting. It is most suitable for viewing photos taken with an sRGB compatible applications such as AutoCAD.• Presentation Is designed for presentations. The brightness is emphasized in this mode to match PC and notebook coloring. This mode accurately represents colors, providing precise and realistic image reproduction, compatible application such as training content.• Vivid Perfecting the balance of color saturation and brightness, is appropriate for playing video clips under ambient light.• 3D Optimized to bring up 3D effects when watching 3D contents.  This mode is only available when 3D function is enabled.• HDR10 Delivers High Dynamic Range effects with higher contrasts of brightness and colors for HDR Blu-ray movies. After auto-detecting metadata or EOTF info from HDR10 contents, HDR10 is available for selection.• HLG Delivers High Dynamic Range effects with higher contrasts of brightness and colors. Picture Mode will be switched to HLG automatically while detecting metadata or EOTF info from HLG streaming contents.• User Recalls the settings customized based on the current available picture modes. Refer to "User Management" on page 29.

There are two user definable modes if the current available picture modes are not suitable for your need. You can use one of the picture modes (except **User**) as a starting point and customize the settings.

• **Load Settings From**

1. Go to **Picture > Picture Mode**.
2. Press ◀/▶ to select **User**.
3. Press ▼ to select **User Management**, then press **OK**. The **User Management** page is displayed.
4. Select **Load Settings From** and press **OK**.
5. Press ▼/▲ to select a picture mode that is closest to your need.
6. Press **OK** and **BACK** to return to the **Picture** menu.
7. Press ▼ to select the submenu item you want to change, and use ◀/▶ to adjust the value. The adjustments define the selected user mode.

User Management

• **Rename User Mode**

Select to rename the customized picture modes (**User**). The new name can be up to 9 characters including English letters (A-Z, a-z), digits (0-9), and space (_).

1. Go to **Picture > Picture Mode**.
2. Press ◀/▶ to select **User**.
3. Press ▼ to select **User Management**, then press **OK**. The **User Management** page is displayed.
4. Press ▼ to select **Rename User Mode**, then press **OK**. The **Rename User Mode** page is displayed.
5. Use ▲/▶/▼/◀ and **OK** to choose the characters you want.
6. When done, press **BACK** to save the changes and exit.

Brightness

The higher the value, the brighter the image. Adjust this control so the black areas of the image appear just as black and that detail in the dark areas is visible.

Contrast

The higher the value, the greater the contrast. Use this to set the peak white level after you have previously adjusted the Brightness setting to suit your selected input and viewing environment.

Sharpness

Adjust the picture to look sharper or softer. The higher the value, the sharper the picture becomes.

Advanced Color Settings

• Gamma Selection

Gamma refers to the relationship between input source and picture brightness.

- **1.8/2.0/2.1**: Select these values according to your preference.
- **2.2/2.3**: Increases the average brightness of the picture. Best for a lit environment, meeting room or family room.
- **2.4/2.5**: Best for viewing movies in a dark environment.
- **2.6**: Best for viewing movies which are mostly composed of dark scenes.
- **BenQ**: Finely-tuned gamma to optimize details and increase contrast.
- **BenQ 2**: Finely-tuned gamma for animation or CG(Computer Graphics). Provide bright and cheerful visual experience.

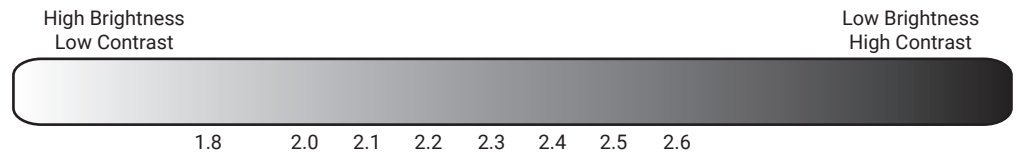

• Color Temperature Tuning

You can set a preferred color temperature by adjusting the following options.

- **R Gain/G Gain/B Gain**: Adjusts the contrast levels of Red, Green, and Blue.
 - **R Offset/G Offset/B Offset**: Adjusts the brightness levels of Red, Green, and Blue.
-

• Color Management

The Color Management provides six sets (RGBCMY) of colors to be adjusted. When you select each color, you can independently adjust its range and saturation according to your preference.

To make adjustments, press the ▲/▼ arrows to highlight an independent color from among Red (R), Green (G), Blue (B), Cyan (C), Magenta (M), or Yellow (Y), and press **OK**. The following menu items are displayed for your choice.

- **Hue:** Increase in the range will include colors consisted of more proportions of its two adjacent colors. Please refer to the illustration for how the colors relate to each other.

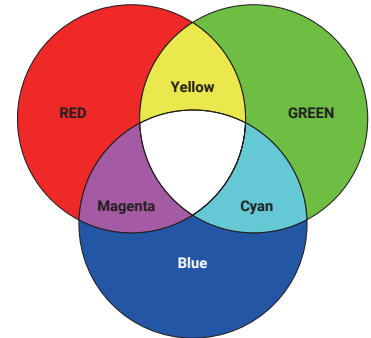

- For example, if you select Red and set its range at 0, only pure red in the projected picture will be selected. Increasing its range will include both the red color close to yellow and red color close to magenta.
- **Saturation:** Adjusts the values to your preference. Every adjustment made will reflect to the image immediately. For example, if you select Red and set its value at 0, only the saturation of pure red will be affected.
 - **Gain:** Adjusts the values to your preference. The contrast level of the primary color you select will be affected. Every adjustment made will reflect to the image immediately.

If you selected **White Balance (W)**, you can adjust the contrast levels of Red, Green, and Blue by selecting **R Gain**, **G Gain**, and **B Gain**.

To return all the settings to the factory default values, highlight **Reset**, and press **OK**.



Saturation is the amount of that color in a video picture. Lower settings produce less saturated colors; a setting of "0" removes that color from the image entirely. If the saturation is too high, that color will be overpowering and unrealistic.

Advanced Color
Settings
(continued)

- **Brilliant Color**

This feature utilizes a new color processing and system level enhancements to enable higher brightness while providing truer, more vibrant colors in picture.

- **Light Source Mode**

Selects a suitable light power from among the provided modes. Refer to "[Extending light source life](#)" on page 60.

- **Custom Brightness**

Adjusts the light power manually. This mode is only available when the **Light Source Mode** is set at **Custom**.

- **HDR Brightness**

The projector can automatically adjust the brightness levels of your image according to the input source. You can also manually select a brightness level to display better picture quality. When the value is higher, the image becomes brighter; when the value is lower, the image becomes darker.

- **Noise Reduction**

Reduces electrical image noise caused by different media players.

Returns all of the adjustments you've made for the selected **Picture Mode** (including the preset mode, **User**) to the factory preset values.

1. Press **OK**. The confirmation message is displayed.
2. Use ◀/▶, select **Reset**, and then press **OK**. The current picture mode returns to the factory preset settings.



The following settings will still remain: **Picture Mode, User Management**.

Advanced Color Settings (continued)

Reset Current Picture Mode

2. Main menu: **Audio**

Structure

Menu	Options
Audio Output	Internal Speaker / 3.5mm Jack
Mute	Off / On
Volume	0 – 20
Power On / Off Ring Tone	Off / On
Reset Audio	Reset / Cancel

Function descriptions

Menu	Descriptions
Audio Output	Selects an audio output source from built-in speakers (Internal Speaker), or the audio output jack (3.5mm Jack).
Mute	Select On to temporarily turn off the projector's internal speaker. To restore the audio, select Off .
Volume	Adjusts the volume level of the projector's internal speaker. If the Mute function is activated, adjusting Volume will turn off the Mute function.
Power On / Off Ring Tone	Sets the ring tone for the projector On or Off . The Power On / Off Ring Tone can only be adjusted here. Setting the sound mute or adjusting the sound level do not affect the Power On / Off Ring Tone .
Reset Audio	Returns all of the adjustments you've done under the Audio menu to the factory preset values.

3. Main menu: **Display**

Structure

Menu	Options			
Aspect Ratio	Auto / Real / 4:3 / 16:9 / 16:10			
Auto Source Search	Auto / Off			
Source Rename	HDMI-1/ HDMI-2			
3D	3D Mode	Top Bottom / Frame Sequential / Frame Packing / Side by Side / Off		
	3D Sync Invert	Disable / Invert		
	Save 3D Settings	3D Settings 1	Yes / No	
		3D Settings 2	Yes / No	
	Apply 3D Settings	3D Settings 1	Yes / No	
		3D Settings 2	Yes / No	
HDMI Settings	HDMI Format	Auto / Limited / Full		
	HDMI Equalizer	HDMI-1	Auto / 1 / 2 / 3 / 4 / 5	
		HDMI-2	Auto / 1 / 2 / 3 / 4 / 5	
	HDMI EDID	HDMI-1	Enhanced / Standard	
		HDMI-2	Enhanced / Standard	
	Electronics Control	Off / On		
	Power On Link	Off / From Device		
Power Off Link	Off / From Projector			
4K Upscaling (LK830ST ONLY)	Off / On			
Screen Fill	Standard-LW830ST	Standard-LH830ST	Standard-LK830ST	
	16:9 (1280 x 720)	16:9 (1920 x 1080)	16:9 (1920 x 1080)	
	16:10 (1280 x 800)	16:10 (1728 x 1080)	16:10 (1728 x 1080)	
	4:3 (1064 x 800)	4:3 (1440 x 1080)	4:3 (1440 x 1080)	
	1:1 (800 x 800)	1:1 (1080 x 1080)	1:1 (1080 x 1080)	
	Enhanced-LW830ST	Enhanced-LH830ST	Enhanced-LK830ST	
	16:9 (1280 x 720)	16:9 (3840 x 2160)	16:9 (3840 x 2160)	
	16:10 (3840 x 2160)	16:10 (1728 x 1080)	16:10 (3456 x 2160)	
	4:3 (1064 x 800)	4:3 (1440 x 1080)	4:3 (2880 x 2160)	
	1:1 (800 x 800)	1:1 (1080 x 1080)	1:1 (2160 x 2160)	
Fast Mode	Off / On			
Blending Ready	Off / On			
Reset Display	Reset / Cancel			

Function descriptions

Menu	Descriptions
Aspect Ratio	<p>There are several options to set the image's aspect ratio depending on your input signal source.</p> <ul style="list-style-type: none">• Auto Scales a picture proportionally to fit the projector's native resolution in its horizontal or vertical width.• Real The input image is shown without scaling. If the input image is smaller than the native resolution of the projector, then the image is centered in the projected image and the area outside of the active area is black.• 4:3 Scales an image so that it is displayed in the center of the screen with a 4:3 aspect ratio.• 16:9 Scales an image so that it is displayed in the center of the screen with a 16:9 aspect ratio.• 16:10 Scales an image so that it is displayed in the center of the screen with a 16:10 aspect ratio.
Auto Source Search	Allows the projector to automatically search for a signal.
Source Rename	Renames the current input source to your desired name.

This projector supports playing three-dimensional (3D) content transferred through your 3D-compatible video devices and contents, such as 3D Blu-ray players (with 3D Blu-ray discs), and so on. After you have connected the 3D video devices to the projector, wear the 3D glasses and make sure the power is on to view 3D contents.

When watching 3D contents:

- The image may seem misplaced; however, this is not a product malfunction.
- Take appropriate breaks when watching 3D contents.
- Stop watching 3D content if you feel fatigue or discomfort.
- Keep a distance from the screen of about three times the effective height of the screen.
- Children and people with a history of oversensitivity to light, heart problems, or any other existing medical conditions should be refrained from watching 3D contents.
- The image may seem reddish, greenish, or bluish without wearing 3D glasses. However, you will not notice any color bias when watching 3D contents with 3D glasses.
- The 4K source will not be displayed.

- **3D Mode**

The default setting is **Off** and the projector automatically chooses an appropriate 3D format when detecting 3D contents. If the projector cannot recognize the 3D format, you can choose **Frame Sequential**, **Frame Packing**, **Top Bottom** or **Side by Side** for it.

When this function is enabled:

- The brightness level of the projected image decreases.
- The **Picture Mode** cannot be adjusted.
- The **2D Keystone** can only be adjusted within limited degrees.

- **3D Sync Invert**

When your 3D image is distorted, enable this function to switch between the image for the left eye and the right eye for more comfortable 3D viewing experience.

- **Save 3D Settings**

When you have successfully displayed the 3D contents after making the appropriate adjustments, you can enable this function and choose a set of 3D settings to memorize current 3D settings.

User could save 2 settings with different sources supporting 3D format.

- **Apply 3D Settings**

After the 3D settings are saved, you can decide if you would like to apply them by choosing a set of 3D settings that you have saved. Once applied, the projector will automatically play the incoming 3D contents if it matches the 3D settings saved.

- **HDMI Format**

Selects a suitable RGB color range to correct the color accuracy.

- **Auto:** Automatically selects a suitable color range for the incoming HDMI signal.
- **Limited:** Utilizes the Limited range RGB 16-235.
- **Full:** Utilizes the Full range RGB 0-255.

- **HDMI Equalizer**

Select HDMI Equalizer value.

- **HDMI EDID**

Switches between **Enhanced** for HDMI 2.0 EDID and **Standard** for HDMI 1.4 EDID. Selecting **Standard** which supports up to 1080p 60Hz may solve abnormal display issues with some old players.

HDMI Settings

- **Electronics Control**

When you enable this function and connect an HDMI CEC-compatible device to your projector with an HDMI cable, turning on the HDMI CEC compatible device automatically turns on the projector, while turning off the projector automatically turns off the HDMI CEC compatible device.

- **HDMI Power On/Off Link**

When you connect an HDMI CEC-compatible device to your projector with an HDMI cable, you can set the behavior of powering on/off between the device and the projector.

Power On Link / Power Off Link > On	When the connected device is turned on, the projector will be activated, too.
	When the projector is turned off, the connected device will be shut down, too.

4K Upscaling (for LK830ST)

Enables or disables "XPR always ON" which upscales all input timings to 4K resolution.

Screen Fill

The native resolution will be changed according to users' selection..

Fast Mode

Minimizing the response time (one frame) between the source input and the image output, in other words, to reduce input lag.

Blending Ready

Customized setting prepared for specific environment.

Switch to **sRGB** picture mode.

Turn off all digital corrections.

Turn on **Direct Power On**.

Turn on **Network Standby Mode**

Ready units to do the blending.

Reset Display



Returns all the settings on the **Display** main menu to the factory default values.

4. Main menu: **Installation**

Structure

Menu	Options		
Projector Position	Front / Front Ceiling / Rear / Rear Ceiling		
2D Keystone	H: -30 – +30 V: -30 – +30		
Auto Vertical Keystone	Off / On		
Test Pattern	Off / On		
High Altitude Mode	Off / On		
Baud Rate	9600 / 14400 / 19200 / 38400 / 57600 / 115200		
Projector ID	Off / 01 / 02 / / 99		
Geometry	Corner Fit	Top Left For LW830ST: H: 0 – 500 / V: 0 – 300 Top Right For LH830ST: H: 0 – 700 / V: 0 – 400 Bottom Left For LK830ST: H: 0 – 1500 / V: 0 – 800 Bottom Right	
	Warping (LK830ST ONLY)	Enable	Off / On
		Warping Pattern	5x3
		Warping Background	Yes / No
		Warping Correction	Yes / No
		Reset	Reset / Cancel
	Digital Zoom	PC signal: 1.0X – 2.0X / Video signal: 1.0X – 2.0X	
	Digital Shrink & Shift	Adjust Value: 0.75x – 1.00x	
	Image Resizing	Modes of adjustment	One Side / Opposite Sides / All 4 sides
		Blanking	Top
Bottom			For LK830ST: 0 – 440
Left			For LW830ST: 0 – 85 For LH830ST: 0 – 125
Right			For LK830ST: 0 – 250
Reset all blanking settings			Reset / Cancel
Wall Color	Off / Light Yellow / Pink / Light Green / Blue / Blackboard		
Image Memory	Save Image Memory	Memory-1 / Memory-2	
	Apply Image Memory	Memory-3 /	
	Rename	Memory-4 / Memory-5	

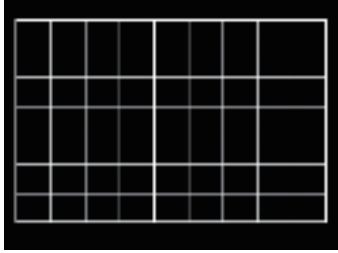
Function descriptions

Menu	Descriptions
Projector Position	The projector can be installed on a ceiling or behind a screen, or with one or more mirrors. See "Choosing a location" on page 14 for details.
2D Keystone	See "Correcting keystone" on page 19 for details.
Auto Vertical Keystone	Automatically corrects the keystone at the top/bottom side of the projected image.
Test Pattern	<p>Adjusts the image size and focus and check that the projected image is free from distortion.</p> <div style="display: flex; align-items: center;">  <p>The below image is for reference only.</p> </div> <div style="text-align: center; margin-top: 10px;">  </div>
High Altitude Mode	<p>We recommend you to use the High Altitude Mode when your environment is between 1500 m - 3000 m above sea level, and ambient temperature is between 0°C to 30°C.</p> <p>Operation under "High Altitude Mode" may cause a higher decibel operating noise level because of increased fan speed necessary to improve overall system cooling and performance.</p> <p>If you use this projector under other extreme conditions excluding the above, it may display auto shut-down symptoms, which is designed to protect your projector from over-heating. In cases like this, you should switch to High Altitude mode to solve these symptoms. However, this is not to state that this projector can operate under any and all harsh or extreme conditions.</p> <div style="display: flex; align-items: center; margin-top: 10px;">  </div> <p>Do not use the High Altitude Mode if your altitude is between 0 m to 1500 m and ambient temperature is between 0°C to 35°C. The projector will be over cooled, if you turn the mode on under such a condition.</p>
Baud Rate	Selects a baud rate that is identical with your computer's so that you can connect the projector with a suitable RS-232 cable and update or download the projector's firmware. This function is intended for qualified service personnel.

Set an ID for projector to match with corresponding remote control.

Sets the projector ID for this projector (between 01~99). When multiple adjacent projectors are in operation at the same time, switching the projector ID codes can prevent interference from other remote controls.

After the Projector ID is set, switch to the same ID for the remote control to control this projector. See "[Projector & Remote control](#)" on page 12.

Set the ID:

1. Press and hold **ID SET** until the ID setting indicator lights up.
2. Enter the ID for the remote control (between 01~99). The remote control ID should be the same as the corresponding projector ID.
3. The ID is saved successfully when you see the ID setting indicator starts flickering and then blackout.

Clear the ID:

1. Press and hold **ID SET** until the ID setting indicator lights up.
 2. Press **ALL** to clear current ID setting of the remote control.
 3. The ID is cleared successfully when you see the ID setting indicator starts flickering and then blackout.
-

• **Corner Fit**

You can manually adjust four corners of the image by setting the horizontal and vertical values.

- Adjust **Corner Fit** will set **Auto Vertical Keystone** to **Off**.
- **Corner Fit** will be set to 0 once **Auto Vertical Keystone** is set to **On**.

• **Warping**

This function aims at correcting the geometric distortion of the projector's images when they are projected onto an uneven surface such as a cylinder, a spherical shape, etc.

When **Screen Fill** is set to **16:10**, **4:3**, or **1:1**, this function is not available.

- **Enable**: When this function is enabled, the following functions are not available: **Keystone**, **Aspect Ratio**, **Corner Fit**, **Digital Shrink & Shift**, **Blanking**, and **Screen Fill**.
- **Warping Pattern**: After the warping function is enabled, select a pattern.



If **Warping** is **Off**, then **Warping Pattern** / **Warping Background** / **Warping Correction** / **Reset** will be grayed out.

- **Warping Background**: Select **Yes** if you want to set the warping data with your projected image. If not, a black screen will be displayed.
-

Projector ID

Geometry

Geometry (continued)

-
- **Warping Correction:** If you have never set the warping data under the selected warping pattern, a grid pattern is displayed.
 1. Press $\blacktriangle/\blacktriangledown/\blacktriangleleft/\blacktriangleright$ to move the cursor to an adjustment point.
 2. Press **OK**.
 3. Press $\blacktriangle/\blacktriangledown/\blacktriangleleft/\blacktriangleright$ to move the adjustment point up/down/left/right. Short press on the directional arrow moves 1 pixel, while long press moves 30 pixels.
 - **Reset:** If you want to set a new warping data for the selected pattern, reset its data first by choosing **Reset**.
-

• Digital Zoom

Magnifies or reduces the projected image size.

1. After the adjustment bar displays, press $\blacktriangle/\blacktriangledown$ on the projector or **ZOOM+/ZOOM-** on the remote control repeatedly to reduce or magnify the image to a desired size.
2. Press **OK** to enter panning mode.
3. Press the directional arrows ($\blacktriangle/\blacktriangledown/\blacktriangleleft/\blacktriangleright$) on the projector or remote control to navigate the picture.



The picture can only be navigated after it is magnified. You can further magnify the picture while searching for details.

• Digital Shrink & Shift

Shrinks and/or shifts the projected image.

1. After the adjustment bar is displayed, press $\blacktriangleleft/\blacktriangleright$ repeatedly to shrink or magnify the picture to a desired size.
2. Press **OK** to activate digital shift function.
3. After digital shift function is activated, press the directional arrows ($\blacktriangle/\blacktriangledown/\blacktriangleleft/\blacktriangleright$) to shift the image.



The picture can only be shifted after it shrank.

• Blanking

Blanks some parts of the projected image.

1. Select the **Modes of Adjustment** first by pressing $\blacktriangleleft/\blacktriangleright$.
2. Press $\blacktriangle/\blacktriangledown$ to highlight the area you want to adjust and press $\blacktriangleleft/\blacktriangleright$ to adjust its range.



Enabling the **Reset All Blanking Settings** function will return all items in the **Blanking** menu to the factory preset values. Pressing **OK** clears the values of selected item.

Image Resizing

Wall Color

Corrects the projected picture's color when the projection surface such as a painted wall which may not be white, the **Wall Color** feature can help correct the projected picture's colors to prevent possible color difference between the source and projected pictures. There are several precalibrated colors to choose from: **Light Yellow, Pink, Light Green, Blue** and **Blackboard**.

Image Memory

- **Save Image Memory**

This function enables users to save and apply a set of image settings they customized for regularly used circumstance by “source” and “timing”, including the following settings: **Projector Position, Aspect Ratio, Picture Mode, Source, Resolution, Light Source Mode, Digital Shrink & Shift, Blanking, Screen Fill, Keystone, Corner Fit, Wall Color, Warping** (for LK830ST). You can choose one set of memory to save the current settings.

- **Apply Image Memory**

After the image memories are saved, you can decide if you would like to apply it by choosing a set of memory that you have saved.

- **Rename**

Renames the image memories. The digits limitation for a name is 10 digits (numbers and characters).

5. Main menu: **System**

Structure

Menu	Options
Language	English / Français / Deutsch / Italiano / Español / Русский / 繁體中文 / 简体中文 / 日本語 / 한국어 / Svenska / Nederlands / Türkçe / Čeština / Português / ไทย / Polski / Hrvatski / Norsk / Dansk / suomi / Bhs Ind / Ελληνικά / العربية / हिन्दी / Tiếng Việt/ فارسی (27 Languages)
Background Settings	Background Color Black / Blue / Purple / Grey Splash Screen BenQ / Black / Blue
Menu Settings	Menu Type Basic / Advanced Menu Display Time 5 sec / 10 sec / 20 sec / 30 sec / Always Menu Position Center / Top-Left / Top-Right / Bottom-Right / Bottom-Left Reminder Message On / Off
Light Source Information	Light Source Usage Time Normal Mode ECO Mode SmartECO Mode Custom Mode Equivalent Light Hours Refer to UM for detailed formula
Power management	Eco Off / On Network Standby Mode Off / On Auto Disable Network Standby Mode Never / 20 min / 1 hr / 3 hr / 6 hr Audio Pass Through Off / HDMI-1 / HDMI-2

	LED Indicator	Off / On
Operation Settings	Power On/Off Settings	Direct Power On Off / On Signal Power On HDMI-1 / HDMI-2 Auto Power Off Disable / 3 min / 10 min / 15 min / 20 min / 25 min / 30 min
	Air Filter Settings	Filter Usage Time Filter time-up Notify OSD / RS-232
	Page Up/Down	Off / On
	Panel Key Lock	Off / On
	Password	Change Password Power On Lock
Security Settings	Wired LAN	Status DHCP IP Address Subnet Mask Default Gateway DNS Server Apply
	AMX Device Discovery	Off / On
	MAC Address (Wired)	
	IR Receiver	IR Front On / Off IR Rear On / Off
	Update Firmware OTA*	Off / On
	Factory Default	Reset / Cancel
	Reset System	Reset / Cancel

Function descriptions

Menu	Descriptions
Language	Sets the language for the On-Screen Display (OSD) menus. <ul style="list-style-type: none"> • Background Color Sets the background color for the projector.
Background Settings	<ul style="list-style-type: none"> • Splash Screen Allows you to select which logo screen will be displayed during projector start-up.

Menu Settings

- **Menu Type**

Sets the OSD menu type according to your needs.

- **Menu Display Time**

Sets the length of time the OSD will remain active after your last key press.

- **Menu Position**

Sets the On-Screen Display (OSD) menu position.

- **Reminder Message**

Sets the reminder messages **On** or **Off**.

This menu page displays the following information:

Light Source Information

- **Light Source Usage Time**

Light used under **Normal Mode**, **ECO Mode**, **SmartECO**, and **Custom Mode**.

- **ECO**

When activated, the projector maintains at normal standby mode with less than 0.5W power consumption.



Changing this setting will make power consumption higher.

- **Network Standby Mode**

When activated, the projector maintains at network standby mode with less than 2W power consumption.

Power management

- **Auto Disable Network Standby Mode**

Allows the projector to disable the network function after a set period of time after it enters standby mode. For instance, if 20 min is selected, the projector is able to provide the network function for 20 minutes after it enters standby mode. When 20 minutes is up, the projector enters **Eco** mode.



- **Audio Pass Through**

The projector can play sound when it is in standby mode and the corresponding jacks are correctly connected to devices. Press ◀/▶ to choose the source that you wish to use. See "[Connection](#)" on page 20 for how to make the connection.

- **LED Indicator**

You can turn off the LED warning lights. This is to avoid any light disturbance when viewing images in a dark room.

- **Power On/Off Settings**

- **Direct Power On:** Allows the projector to turn on automatically once the power is fed through the power cord.
- **Signal Power On:** Sets whether to turn the projector directly on without pressing  **POWER** or  **ON** when the projector is in standby mode and detects a HDMI signal.
- **Auto Power Off:** Allows the projector to turn off automatically if no input signal is detected after a set period of time to prevent unnecessary waste of light source life.

Operation Settings



Changing this setting will make power consumption higher.

- **Air Filter Settings**

- **Filter Usage Time:** System will start counting filter usage time automatically and shows the number of hours the filter has been used.
- **Filter time-up Notify:** User can select the way to receive filter time-up notification.





OSD/RS232 cannot be **Off** at the same time.

- **Page Up/Down**

When this function is enabled, the **PAGE+** / **PAGE-** buttons on the remote control can be used to perform page up/down commands.

• Panel Key Lock

With the control keys on the projector locked, you can prevent your projector settings from being changed accidentally (by children, for example). When the **Panel Key Lock** is **On**, no control keys on the projector will operate except for  **POWER**.

To release panel key lock, press and hold  (the right key) on the projector for 3 seconds. Or you can use the remote control to disable **Panel Key Lock**.









If you turn off the projector without disabling panel key lock, the projector will still be in locked status the next time it is turned on.

• Password

Change password.

Utilizing the password function

Setting a password:

1. Go to Advanced menu - System > Security Settings > Password. Press **OK**. The Password page appears.
2. Highlight **Change Password** and press **OK**.
3. The four arrow keys (, , , ) respectively represent 4 digits (1, 2, 3, 4). According to the password you desire to set, press the arrow keys to enter six digits for the password.
4. Confirm the new password by re-entering the new password.
5. To activate the **Power On Lock** function, go to System > Security Settings > Password > Power On Lock, press **OK** and   to select **On**. Input the password again.



- The digits being input will display as asterisks on-screen. Make a note of your selected password and keep it in a safe place in advance or right after the password is entered so that it is available to you should you ever forget it.
- Once a password has been set and the **Power On Lock** is activated, the projector cannot be used unless the correct password is entered every time the projector is started.

If you forget the password:

If you enter the wrong password, the password error message will appear, and the Input Password message follows. If you absolutely do not remember the password, you can use the password recall procedure (please refer to the next section). If you enter an incorrect password 5 times in succession, the projector will automatically shut down in a short time.

Entering the password recall procedure:

1. Press and hold **OK** for 3 seconds. The projector will display a coded number on the screen.
2. Write down the number and turn off your projector.
3. Seek help from the local BenQ service center to decode the number. You may be required to provide proof of purchase documentation to verify that you are an authorized user of the projector.

Changing the password:

1. Go to Advanced menu - System > Security Settings > Password. Press **OK**. The Password page appears.
2. Highlight **Change Password** and press **OK**.
3. Enter the old password.
 - If the password is correct, another message Input New Password appears.
 - If the password is incorrect, the password error message will appear, and the message Input Current Password appears for your retry. You can press **BACK** to cancel the change or try another password.
4. Enter a new password.
5. Confirm the new password by re-entering the new password.

Disabling the password function:

To disable password protection, go to Advanced menu - System > Security Settings > Password > Power On Lock and press **OK** and **◀/▶** to select **Off**. The message Input Password appears. Enter the current password.

- If the password is correct, the OSD menu will disappear. You will not have to enter the password next time turning on the projector.
- If the password is incorrect, the password error message will appear, and the message Input Current Password appears for your retry. You can press **BACK** to cancel the change or try another password.



Though the password function is disabled, you need to keep the old password in hand should you ever need to re-activate the password function by entering the old password.

• **Wired LAN**

Adjust the wired network settings of projector.

Connecting the projector to the Internet

If you are in a DHCP environment:

1. Take a RJ45 cable and connect one end to the RJ45 LAN input jack of the projector and the other end to the RJ45 port.



When connecting the RJ45 cable, avoid coiling and intertwining the cable as it may cause signal noise or interruption.

2. Make sure the menu type is Advanced. See ["Using the menus" on page 22](#) for how to switch to the Advanced OSD menu.
3. Go to the Advanced menu - System > Network Settings menu.
4. Highlight **Wired LAN** and then press **OK**. The Wired LAN page is displayed.
5. Press **▲/▼** to highlight **DHCP** and press **◀/▶** to select **On**.
6. Press **▲/▼** to highlight **Apply** and press **OK**.
7. Go back to the Network Standby Mode page.
8. Press **▲/▼** to highlight **AMX Device Discovery** and press **◀/▶** to select **On** or **Off**. When **AMX Device Discovery** is **On**, the projector can be detected by AMX controller.
9. Please wait for around 15 ~ 20 seconds, and then re-enter the Wired LAN page.
10. The **IP Address**, **Subnet Mask**, **Default Gateway**, and **DNS Server** settings will be displayed.

Take a note of the IP address displayed in the **IP Address** row.



If the **IP Address** still does not display, contact your ITS administrator.

Network Settings

If you are in a non-DHCP environment:

1. Repeat steps 1 ~ 4 in the "If you are in a DHCP environment:" section.
2. Press ▲/▼ to highlight **DHCP** and press ◀/▶ to select **Off**.
3. Contact your ITS administrator for information on the **IP Address**, **Subnet Mask**, **Default Gateway**, and **DNS Server** settings.
4. Press ▲/▼ to select the item you want to modify and press **OK**.
5. Press ◀/▶ to move the cursor and then press ▲/▼ to enter the value.
6. To save the setting, press **OK**. If you do not want to save the setting, press **BACK**.
7. Press ▲/▼ to highlight **Apply** and press **OK**.
8. Press **BACK** to return to Wired LAN page, press ▲/▼ to highlight **AMX Device Discovery** and press ◀/▶ to select **On** or **Off**.
9. Press **BACK** to exit the menu.

10. AMX Device Discovery

When **AMX Device Discovery** is on, the projector can be detected by AMX controller.

- **MAC Address (Wired)**

Always show the MAC address of the projector.

This function is only supported by projectors with wired LAN.

For network security reasons, please set an administrator password via a browser before using the network control function for the first time.

Step 1: Connect your computer and projector to the same network.

Step 2: Open a browser and enter the projector's IP address in the URL field.

Step 3: Set your account and password via the browser and keep it safe.

Network Settings (continued)

IR Receiver

To enable or disable selected remote receiver.

Update Firmware OTA*

For LW830ST, this item will be "Device Firmware Auto Update"

Upgrades the firmware. Refer to ["Upgrades the firmware" on page 24](#).

Factory Default

Returns all settings to the factory preset values.



The following settings will remain: **Projection Position**, **2D Keystone**, **Auto Vertical Keystone**, **High Altitude Mode**, **Baud Rate**, **Projector ID**, **Geometry**, **Digital Shrink & Shift**, **Blanking**, **Wall Color**, **Filter Usage Time**, **Filter Timer**, **Security Settings**, **Network Settings**.

Reset System

Returns all the settings on the **System** main menu to the factory default values.



The following settings will remain: **Filter Usage Time**, **Filter Timer**, **Security Settings**, **Network Settings**, **IR Receiver**.

6. Main menu: **Information**

Function descriptions

Menu	Descriptions
Native Resolution	Shows the native resolution of the projector.
Detected Resolution	Shows the detected resolution of the input signal.
Source	Shows the current signal source.
Picture Mode	Shows the selected mode on the Picture menu.
Light Source Mode	Shows the used light source mode.
3D Format	Shows the current 3D mode.  3D Format is only available when 3D is enabled.
Color System	Shows the input system format.
Dynamic Range	Shows the picture dynamic range, e.g. SDR, HDR10, HLG, etc.
Light Source Usage Time	Shows the number of hours the light has been used.
Projector ID	Shows projector ID of the projector.
Firmware Version	Displays the firmware version of your projector.
Service Code	Shows the service code of your projector.

Controlling projector with a mobile device

Installing the InstaControl app on a mobile device

- Search for the InstaControl app from Google Play Store (Android) or App Store (iOS).



- For user in China, scan below QR code:



Voice control functions are not available in China.

Connecting the BT dongle

Insert BT dongle (FSC-BP10Y) into the projector that you would like to control. See "[Connection](#)" on page 20 for how to make the connection.



Please contact your local support team for assistance with product availability.

Pairing the InstaControl app and BT dongle

1. Press the **Power** button on the projector or remote control to start the projector.
 2. Launch InstaControl app on your mobile device.
-



Enabling your Bluetooth allows our app to seamlessly connect with nearby devices.

3. Select **Connect**.



4. Select the projector that you would like to control.



iOS



Android



Only one projector can be connected to the mobile via dongle at a time.

Controlling the projector with a mobile device



iOS



Android

1. Power
Toggles the projector between standby mode and on.
2. ECO Blank + Mute
Used to hide the screen image and mute audio.
3. Geometry
Adjusts the projector keystone and four corners.



• Adjustments consist of a combination of projector OSD and app settings and both of them will be reset while selecting **Reset**.



iOS

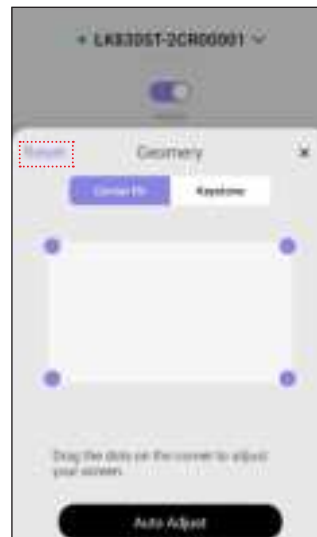

Android



- Adjustments consist of a combination of projector OSD and app settings and both of them will be reset while selecting **Auto Fit to Screen** or **Avoid Obstacles**.



iOS

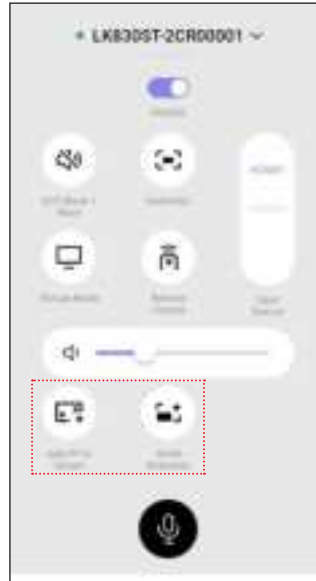

Android

4. Input Source
Select your desired input signal.
5. Picture Mode
Displays the picture mode menu on the mobile device.
6. Remote Control
Displays the keypad.

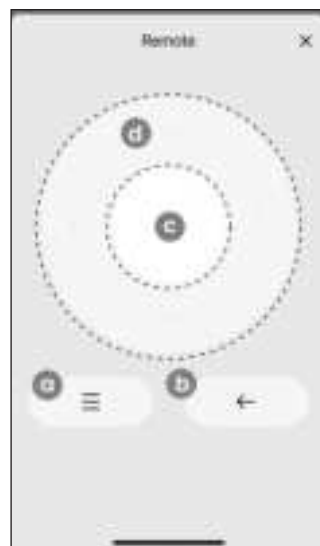

iOS

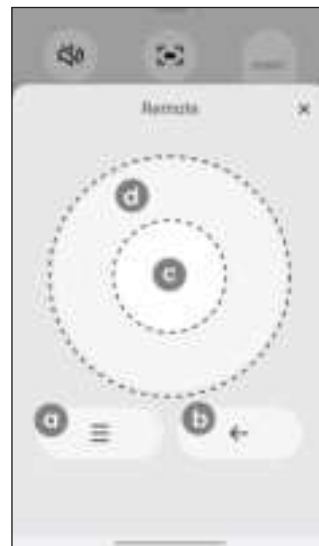

Android

- a. Menu
Turns on/off the On-Screen Display (OSD) menu.
- b. Back
Goes back to the previous OSD menu, exits and saves the menu settings.
- c. OK
Confirms the selected On-Screen Display (OSD) menu item.

d. Arrow keys

When the On-Screen Display (OSD) menu is activated, these keys are used as 4 directional arrows to select the desired menu items and to make adjustments.

7. Volume

Adjusts the volume level.

8. Auto Fit to Screen

Using the mobile camera to capture a pattern projected to get image fit into physical screen, further adjustments can be made in **Geometry**.



- The physical screen you use is flat without curves or bumps.
- The pattern is visible, unobscured, or unbroken throughout process.
- The pattern is in the range of your physical screen.
- Go to **Geometry**, tap **Reset** to restore the previous settings.



iOS

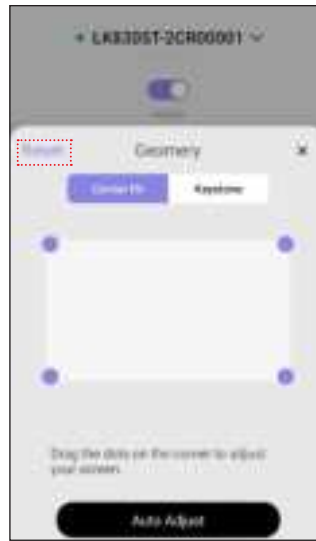

Android

9. Avoid Obstacles

Using the mobile camera to capture a pattern projected to avoid the object, further adjustments can be made in **Geometry**.



- The physical screen you use is flat without curves or bumps.
- The pattern is visible, unobscured, or unbroken throughout process.
- The pattern is in the range of your physical screen.
- Go to **Geometry**, tap **Reset** to restore the previous settings.



iOS

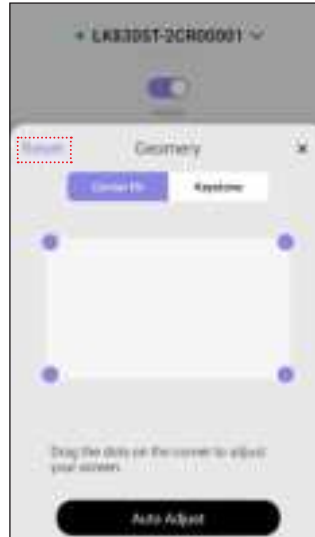

Android

10. Voice control

Using voice to interact with the projector.

Voice-enabled features:

- Turn off the projector
- Adjusts the volume level of the projector's internal speaker
- Hide the screen image (ECO Blank and Mute)
- Switching the input signal
- Choose the picture mode



- If the projector cannot be controlled via voice commands, it may be because the daily usage limit for voice control has been reached.
 - Voice control functions are not available in China.
-

Unpairing and linking to another projector

1. On the top of the control panel, tap **CONNECTED**.
2. Select **Disconnect** to unpair or select **Link to Another Device** to pair with another projector.



iOS



Android



Only one projector can be connected to the mobile via dongle at a time.

Maintenance

Care of the projector

Cleaning the lens

Clean the lens whenever you notice dirt or dust on the surface. Be sure to turn off the projector and let it cool down completely before cleaning the lens.

- Use a canister of compressed air to remove dust.
- If there is dirt or smears, use lens-cleaning paper or moisten a soft cloth with lens cleaner and gently wipe the lens surface.
- Never use any type of abrasive pad, alkaline/acid cleaner, scouring powder, or volatile solvent, such as alcohol, benzene, thinner or insecticide. Using such materials or maintaining prolonged contact with rubber or vinyl materials may result in damage to the projector surface and cabinet material.

Please note that it is normal to have some dust on the lens surface. If it needs lens clean, please never remove any parts of the projector.

Contact your dealer or local customer service center if the projector fails to operate as expected.

Cleaning the projector case

Before you clean the case, turn the projector off using the proper shutdown procedure as described in "[Shutting down the projector](#)" on page 25 and unplug the power cord.

- To remove dirt or dust, wipe the case with a soft, lint-free cloth.
- To remove stubborn dirt or stains, moisten a soft cloth with water and a neutral pH detergent. Then wipe the case.



Never use wax, alcohol, benzene, thinner or other chemical detergents. These can damage the case.

Storing the projector

If you need to store the projector for an extended time, please follow the instructions below:

- Make sure the temperature and humidity of the storage area are within the recommended range for the projector. Please refer to "[Specification](#)" on page 63 or consult your dealer about the range.
- Retract the adjuster feet.
- Remove the battery from the remote control.
- Pack the projector in its original packing or equivalent.

Transporting the projector

It is recommended that you ship the projector with its original packing or equivalent.

Light Source Information

Getting to know the light source hour

When the projector is in operation, the duration (in hours) of light source usage is automatically calculated by the built-in timer. The method of calculating is as follows:

Light Usage Time = (x+y+a) hours, if

Time used in the **Normal** mode = x hours

Time used in the **ECO** mode = y hours

Time used in the **Custom** mode = a hours



For time used in each light source mode shown in OSD menu:

- Time used is accumulated and rounded down to an integer in **hours**.
- When time used is less than 1 hour, it shows 0 hours.

To obtain the light source information:

Go to **Advanced Menu - System > Light Source Information**, then press **OK**. The **Light Source Information** page is displayed.

You can also get the light hour information on the **Information** menu.

Extending light source life

• Setting **Light Source Mode**

Go to **Advanced Menu - Picture > Advanced Color Settings > Light Source Mode** and press **◀/▶** to select a suitable light source power from among the provided modes.

Setting the projector in **ECO**, or **Custom** mode extends light life.

Light Source Mode	Descriptions
Normal	Provides full light brightness.
ECO	Lowers brightness to extend the light source life and decreases the fan noise.
SmartECO	Adjusts the light power automatically from 30% to 100% (check by model) and Brightness / 30% to 100% (check by model) power depending on the content.
Custom	Adjusts the light power manually from 30% to 100% in 1% increments.

• Setting **Auto Power Off**

This function allows the projector to turn off automatically if no input signal is detected after a set period of time to prevent unnecessary waste of light source life.

To set **Auto Power Off**, go to **Advanced Menu - System > Operation Settings > Power On/Off Settings > Auto Power Off** and press **◀/▶** to set the time period.

































































The light source (LED) can last around 20,000-30,000 hours and no need to be changed during the lifetime of the projector mostly. When it is needed, light source replacement is not user-serviceable. Please contact the service center for assistance.





Changing this setting will make power consumption higher.

Indicator

POWER	TEMP	LIGHT	Status & Description
System Information			
			Stand-by mode
			Powering up
			Normal operation
			Normal power-down cooling
			DLP/MCU/LAN Downloading
			Color wheel start failure
			Phosphor Wheel start failure
			LAN download failure
			MCU download failure
			DLP download failure
Burn-In Information			
			Burn-In On
			Burn-In Off
Light Source Information			
			Lightsource error in normal operation
Thermal information			
			Fan 1 error (the actual fan speed is outside the desired speed)
			Fan 2 error (the actual fan speed is outside the desired speed)
			Temperature 1 error (over limited ambient temperature)
			Thermal IC #1 I2C Connection error
			Thermal Sensor 2 open error
			Thermal Sensor 2 short error

 : Off
  : Orange on
  : Green On
  : Red On

 : Orange Flashing
  : Green Flashing
  : Red Flashing

Troubleshooting

? The projector does not turn on.

Cause	Remedy
There is no power from the power cord.	Plug the power cord into the AC power jack on the projector, and plug the power cord into the power outlet. If the power outlet has a switch, make sure that it is switched on.

? No picture

Cause	Remedy
The video source is not turned on.	Turn the video source on and check that the signal cable is connected correctly.
The projector is not correctly connected to the input signal device.	Check the connection.
The input signal has not been correctly selected.	Select the correct input signal with the SOURCE key.

? Blurred image

Cause	Remedy
The projection lens is not correctly focused.	Adjust the focus of the lens using the focus ring.
The projector and the screen are not aligned properly.	Adjust the projection angle and direction as well as the height of the projector if necessary.

? Remote control does not work.

Cause	Remedy
The batteries are out of power.	Replace both of the batteries with new ones.
There is an obstacle between the remote control and the projector.	Remove the obstacle.
You are too far away from the projector.	Stand within 8 meters (26 feet) of the projector.

Specification

Projector specifications



All specifications are subject to change without notice.

Optical

Resolution

- LH830ST: 1920 x 1080
- LK830ST: 3840 x 2160
- LW830ST: 1280 x 800

Display system

1-CHIP DMD

Lens

Throw ratio:

LH830ST/LK830ST: 0.496

LW830ST: 0.521

Projection range

70" - 300"

Light source

Laser

Electrical

External power supply

AC 100 - 240V, 50 - 60

Power consumption

250 W (Max); < 0.5 W (Standby)

Mechanical

Weight

- LH830ST: 3.4 Kg ± 100 g (7.49 ± 0.22 lbs)
- LK830ST: 3.6 Kg ± 100 g (7.93 ± 0.22 lbs)
- LW830ST: 3.4 Kg ± 100 g (7.49 ± 0.22 lbs)

Output terminals

Audio signal output

Audio line out

Input terminals

Digital

- HDMI-1 (2.0b, HDCP 2.2)
- HDMI-2 (2.0b, HDCP 2.2)

Control

RS-232 serial control

9 pin x 1

IR receiver x 2

LAN control

RJ-45 x 1 (10/100Mbps)

USB

- USB (Type A)
- SERVICE (Type A, 5V 1.5A) for FW update

Environmental Requirements

Operating temperature

0°C - 40°C at sea level

Storage temperature

-20°C - 60°C at sea level

Operating/Storage relative humidity

10% - 80% / 5% - 90% (without condensation)

Operating altitude

0 - 1499 m at 0°C - 35°C

1500 - 3000 m at 0°C - 30°C (with High Altitude Mode on)

Storage altitude

30°C @ 0 - 12,200 m above sea level

Repairing

Please visit below website and choose your country to find your service contact window.
<http://www.benq.com/welcome>

Transporting

Original packing or equivalent is recommended.

Dimensions

Projector dimensions

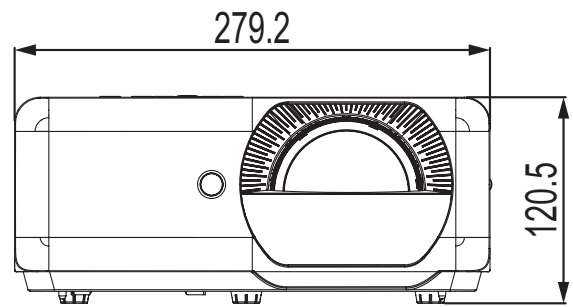
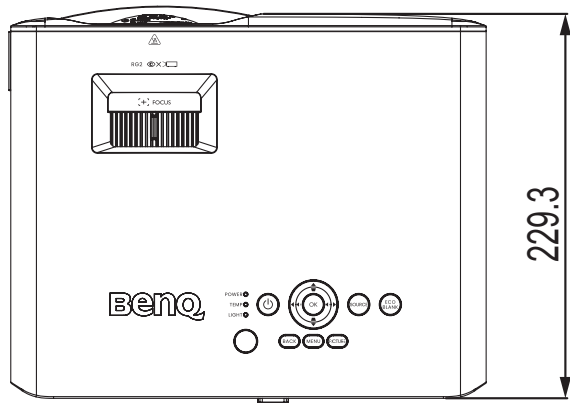

Unit: mm

Timing chart

Supported timing for HDMI (HDCP) input

• PC timings

Resolution	Mode	Refresh Rate (Hz)	Horizontal Frequency (kHz)	Clock (MHz)	3D Frame Sequential	3D Over-Under	3D Side-by-Side
720 x 400	720 x 400_70	70.087	31.469	28.3221			
640 x 480	VGA_60	59.940	31.469	25.175	V	V	V
	VGA_72	72.809	37.861	31.500			
	VGA_75	75.000	37.500	31.500			
	VGA_85	85.008	43.269	36.000			
800 x 600	SVGA_60	60.317	37.879	40.000	V	V	V
	SVGA_72	72.188	48.077	50.000			
	SVGA_75	75.000	46.875	49.500			
	SVGA_85	85.061	53.674	56.250			
	SVGA_120 (Reduce Blanking)	119.854	77.425	83.000	V		
1024 x 768	XGA_60	60.004	48.363	65.000	V	V	V
	XGA_70	70.069	56.476	75.000			
	XGA_75	75.029	60.023	78.750			
	XGA_85	84.997	68.667	94.500			
	XGA_120 (Reduce Blanking)	119.989	97.551	115.500	V		
1152 x 864	1152 x 864_75	75.00	67.500	108.000			
1024 x 576	BenQ NB Timing	60.0	35.820	46.966			
1024 x 600	BenQ NB Timing	64.995	41.467	51.419			
1280 x 720	1280 x 720_60	60	45.000	74.250	V	V	V
	1280 x 720_120	120	90.000	148.500	V		
1280 x 768	1280 x 768_60 (Reduce Blanking)	60	47.396	68.25	V	V	V
	1280 x 768_60	59.870	47.776	79.5	V	V	V
1280 x 800	WXGA_60	59.810	49.702	83.500	V	V	V
	WXGA_75	74.934	62.795	106.500			
	WXGA_85	84.880	71.554	122.500			
	WXGA_120 (Reduce Blanking)	119.909	101.563	146.25	V		
1280 x 1024	SXGA_60	60.020	63.981	108.000		V	V
	SXGA_75	75.025	79.976	135.000			
	SXGA_85	85.024	91.146	157.500			
1280 x 960	1280 x 960_60	60.000	60.000	108		V	V
	1280 x 960_85	85.002	85.938	148.500			
1360 x 768	1360 x 768_60	60.015	47.712	85.500		V	V
1440 x 900	WXGA+_60 (Reduce Blanking)	60	55.469	88.75		V	V
	WXGA+_60	59.887	55.935	106.500		V	V
1400 x 1050	SXGA+_60	59.978	65.317	121.750		V	V

1600 x 1200	UXGA	60.000	75.000	162.000		V	
1680 x 1050	1680x1050_60 (Reduce Blanking)	59.883	64.674	119.000		V	V
	1680x1050_60	59.954	65.290	146.250		V	V
640 x 480 @67Hz	MAC13	66.667	35.000	30.240			
832 x 624 @75Hz	MAC16	74.546	49.722	57.280			
1024 x 768 @75Hz	MAC19	75.020	60.241	80.000			
1152 x 870 @75Hz	MAC21	75.06	68.68	100.00			
1920 x 1080@60 Hz	1920 x 1080_60 (CEA-861)	60	67.5	148.5	V	V	V
1920 x 1200@60 Hz	1920 x 1200_60 (Reduce Blanking)	59.95	74.038	154	V	V	V
1920 x 1080@120 Hz (#)	1920 x 1080_120	120.000	135.000	297			
1920 x 1200@120Hz (#)	1920 x 1200_120 (Reduce Blanking)	119.909	152.404	317.00			
2560 x 1440@60Hz (#)	2560 x 1440_60	59.951	88.787	241.5			
2560 x 1440@120Hz (#)	2560 x 1440_120 (Reduce Blanking) For gaming model	119.998	182.996	497.75			
2560 x 1600 (#)	2560 x 1600_60 (Reduce Blanking) For 4K2K model	59.972	98.713	268.5			
2560 x 1600 (VESA) (#)	2560 x 1600_60	59.987	99.458	348.5			
3840 x 2160	3840 x 2160_30 (Reduce Blanking) For 4K2K model	29.97	65.66	257.404			
3840 x 2160	3840 x 2160_30 For 4K2K model	30	67.5	297			
3840 x 2160	3840 x 2160_60 For 4K2K model	60	135	594			
4096 x 2160	4096 x 2160_60 (Reduce Blanking) For 4K2K model	60	133.32	556.744			
4096 x 2160	4096 x 2160_60	60	135	594			



- V: Supports manually setting 3D format.
- (#): Supported only in LK830ST model.
- The timings showing above may not be supported due to EDID file and VGA graphic card limitations. It is possible that some timings cannot be chosen.

• Video timings

Timing	Resolution	Horizontal Frequency (KHz)	Vertical Frequency (Hz)	Dot Clock Frequency (MHz)	3D Frame Sequential	3D Frame Packing	3D Over-Under	3D Side-by-Side
480i	720(1440) x 480	15.73	59.94	27				
480p	720 x 480	31.47	59.94	27				
576i	720(1440) x 576	15.63	50	27				
576p	720 x 576	31.25	50	27				
720/50p	1280 x 720	37.5	50	74.25		▲	▲	▲
720/60p	1280 x 720	45.00	60	74.25	V	▲	▲	▲
1080/24P	1920 x 1080	27	24	74.25		▲	▲	▲
1080/25P	1920 x 1080	28.13	25	74.25				
1080/30P	1920 x 1080	33.75	30	74.25				
1080/50i	1920 x 1080	28.13	50	74.25				▲
1080/60i	1920 x 1080	33.75	60	74.25				▲
1080/50P	1920 x 1080	56.25	50	148.5			▲	▲
1080/60P	1920 x 1080	67.5	60	148.5	V		▲	▲
1080/120p (#)	1920 x 1080	135	120	297	V			
2160/24P	3840 x 2160	54	24	297				
2160/25P	3840 x 2160	56.25	25	297				
2160/30P	3840 x 2160	67.5	30	297				
2160/50P	3840 x 2160	112.5	50	594				
2160/60P	3840 x 2160	135	60	594				
2160/24P	4096 x 2160	54	24	297				
2160/25P	4096 x 2160	56.25	25	297				
2160/30P	4096 x 2160	67.5	30	297				
2160/50P	4096 x 2160	112.5	50	594				
2160/60P	4096 x 2160	135	60	594				



- ▲: Supports auto-detecting and manually setting 3D format.
- V: Supports manually setting 3D format.
- (#): Supported only in LK830ST model.
- (*): Supported only in LH830ST model.
- The timings showing above may not be supported due to EDID file and VGA graphic card limitations. It is possible that some timings cannot be chosen.

RS232 command

RS232 pin assignment

No.	Serial	No.	Serial
1	NC	6	NC
2	RX	7	RTSZ
3	TX	8	CTSZ
4	NC	9	NC
5	GND		



Function	Type	Operation	ASCII
Power	Write	Power On	<CR>*pow=on#<CR>
	Write	Power Off	<CR>*pow=off#<CR>
	Read	Power Status	<CR>*pow=?#<CR>
Source Selection	Write	HDMI1(MHL)	<CR>*sour=hdmi#<CR>
	Write	HDMI 2(MHL2)	<CR>*sour=hdmi2#<CR>
	Read	Current source	<CR>*sour=?#<CR>
Audio Control	Write	Mute On	<CR>*mute=on#<CR>
	Write	Mute Off	<CR>*mute=off#<CR>
	Read	Mute Status	<CR>*mute=?#<CR>
	Write	Volume +	<CR>*vol=+#<CR>
	Write	Volume -	<CR>*vol=-#<CR>
	Write	Volume level for customer	<CR>*vol=value#<CR>
	Read	Volume Status	<CR>*vol=?#<CR>
Audio Source Select	Write	Audio pass Through off	<CR>*audiosour=off#<CR>
	Write	Audio-HDMI	<CR>*audiosour=hdmi#<CR>
	Write	Audio-HDMI2	<CR>*audiosour=hdmi2#<CR>
	Read	Audio pass Status	<CR>*audiosour=?#<CR>
Picture Mode	Write	Presentation	<CR>*appmod=preset#<CR>
	Write	Simulation	<CR>*appmod=simulation#<CR>
	Write	sRGB	<CR>*appmod=srgb#<CR>
	Write	Bright	<CR>*appmod=bright#<CR>
	Write	Vivid	<CR>*appmod=vivid#<CR>
	Write	User1	<CR>*appmod=user1#<CR>
	Write	User2	<CR>*appmod=user2#<CR>
	Read	Picture Mode	<CR>*appmod=?#<CR>

Function	Type	Operation	ASCII
Picture Setting	Write	Contrast +	<CR>*con=+#<CR>
	Write	Contrast -	<CR>*con=-#<CR>
	Write	Set Contrast value	<CR>*con=value#<CR>
	Read	Contrast value	<CR>*con=?#<CR>
	Write	Brightness +	<CR>*bri=+#<CR>
	Write	Brightness -	<CR>*bri=-#<CR>
	Write	Set Brightness value	<CR>*bri=value#<CR>
	Read	Brightness value	<CR>*bri=?#<CR>
	Write	Sharpness +	<CR>*sharp=+#<CR>
	Write	Sharpness -	<CR>*sharp=-#<CR>
	Write	Set Sharpness value	<CR>*sharp=value#<CR>
	Read	Sharpness value	<CR>*sharp=?#<CR>
	Write	Aspect 4:3	<CR>*asp=4:3#<CR>
	Write	Aspect 16:9	<CR>*asp=16:9#<CR>
	Write	Aspect 16:10	<CR>*asp=16:10#<CR>
	Write	Aspect Auto	<CR>*asp=AUTO#<CR>
	Write	Aspect Real	<CR>*asp=REAL#<CR>
	Read	Aspect Status	<CR>*asp=?#<CR>
	Write	Vertical Keystone +	<CR>*vkeystone=+#<CR>
	Write	Vertical Keystone -	<CR>*vkeystone=-#<CR>
	Write	Vertical Keystone value Set	<CR>*vkeystone=value#<CR>
	Read	Vertical Keystone value	<CR>*vkeystone=?#<CR>
	Write	Horizontal Keystone +	<CR>*hkeystone=+#<CR>
	Write	Horizontal Keystone -	<CR>*hkeystone=-#<CR>
	Write	Horizontal Keystone value Set	<CR>*hkeystone=value#<CR>
	Read	Horizontal Keystone value	<CR>*hkeystone=?#<CR>
	Write	4 Corners Top-Left-X Decrease	<CR>*cornerfittlx=-#<CR>
	Write	4 Corners Top-Left-X Increase	<CR>*cornerfittlx=+#<CR>
	Read	4 Corners Top-Left-X Status	<CR>*cornerfittlx=?#<CR>
	Write	4 Corners Top-Left-Y Decrease	<CR>*cornerfittly=-#<CR>
Write	4 Corners Top-Left-Y Increase	<CR>*cornerfittly=+#<CR>	
Read	4 Corners Top-Left-Y Status	<CR>*cornerfittly=?#<CR>	

Function	Type	Operation	ASCII
Picture Setting (continued)	Write	4 Corners Top-Right-X Decrease	<CR>*cornerfitrx=-#<CR>
	Write	4 Corners Top-Right-X Increase	<CR>*cornerfitrx=+#<CR>
	Read	4 Corners Top-Right-X Status	<CR>*cornerfitrx=?#<CR>
	Write	4 Corners Top-Right-Y Decrease	<CR>*cornerfitry=-#<CR>
	Write	4 Corners Top-Right-Y Increase	<CR>*cornerfitry=+#<CR>
	Read	4 Corners Top-Right-Y Status	<CR>*cornerfitry=?#<CR>
	Write	4 Corners Bottom-Left-X Decrease	<CR>*cornerfitblx=-#<CR>
	Write	4 Corners Bottom-Left-X Increase	<CR>*cornerfitblx=+#<CR>
	Read	4 Corners Bottom-Left-X Status	<CR>*cornerfitblx=?#<CR>
	Write	4 Corners Bottom-Left-Y Decrease	<CR>*cornerfitbly=-#<CR>
	Write	4 Corners Bottom-Left-Y Increase	<CR>*cornerfitbly=+#<CR>
	Read	4 Corners Bottom-Left-Y Status	<CR>*cornerfitbly=?#<CR>
	Write	4 Corners Bottom-Right-X Decrease	<CR>*cornerfitbrx=-#<CR>
	Write	4 Corners Bottom-Right-X Increase	<CR>*cornerfitbrx=+#<CR>
	Read	4 Corners Bottom-Right-X Status	<CR>*cornerfitbrx=?#<CR>
	Write	4 Corners Bottom-Right-Y Decrease	<CR>*cornerfitbry=-#<CR>
	Write	4 Corners Bottom-Right-Y Increase	<CR>*cornerfitbry=+#<CR>
	Read	4 Corners Bottom-Right-Y Status	<CR>*cornerfitbry=?#<CR>
	Write	Digital Zoom In	<CR>*zoomI#<CR>
	Write	Digital Zoom out	<CR>*zoomO#<CR>
	Write	Brilliant color on	<CR>*BC=on#<CR>
	Write	Brilliant color off	<CR>*BC=off#<CR>
	Read	Brilliant color status	<CR>*BC=?#<CR>
	Write	Noise Reduction	<CR>*noiserdt=value#<CR>
	Read	Noise Reduction status	<CR>*noiserdt=?#<CR>
	Write	Reset current picture settings	<CR>*rstcurpicsetting#<CR>

Function	Type	Operation	ASCII
Operation Settings	Write	Projector Position-Front Table	<CR>*pp=FT#<CR>
	Write	Projector Position-Rear Table	<CR>*pp=RE#<CR>
	Write	Projector Position-Rear Ceiling	<CR>*pp=RC#<CR>
	Write	Projector Position-Front Ceiling	<CR>*pp=FC#<CR>
	Read	Projector Position Status	<CR>*pp=?#<CR>
	Write	Menu Position - Center	<CR>*menuposition=center#<CR>
	Write	Menu Position - Top-Left	<CR>*menuposition=tl#<CR>
	Write	Menu Position - Top-Right	<CR>*menuposition=tr#<CR>
	Write	Menu Position - Bottom-Right	<CR>*menuposition=br#<CR>
	Write	Menu Position - Bottom-Left	<CR>*menuposition=bl#<CR>
	Read	Menu Position Status	<CR>*menuposition=?#<CR>
	Write	Direct Power On-on	<CR>*directpower=on#<CR>
	Write	Direct Power On-off	<CR>*directpower=off#<CR>
	Read	Direct Power On-Status	<CR>*directpower=?#<CR>
	Write	Signal Power On-off	<CR>*autopower=off#<CR>
	Write	Signal Power On-on	<CR>*autopower=on#<CR>
	Write	Signal Power On-standard	<CR>*autopower=standard#<CR>
	Write	Signal Power On-advanced	<CR>*autopower=advanced#<CR>
	Read	Signal Power On-Status	<CR>*autopower=?#<CR>
	Write	Standby Settings-Network on	<CR>*standbynet=on#<CR>
	Write	Standby Settings-Network off	<CR>*standbynet=off#<CR>
	Read	Standby Settings-Network Status	<CR>*standbynet=?#<CR>
	Write	Power Management Eco On	<CR>*powermanagementeco=on#<CR>
	Write	Power Management Eco Off	<CR>*powermanagementeco=off#<CR>
	Read	Power Management Eco Status	<CR>*powermanagementeco=?#<CR>
	Write	FW OTA Detect on	<CR>*fwotadetect=on#<CR>
	Write	FW OTA Detect off	<CR>*fwotadetect=off#<CR>
Read	FW OTA Detect status	<CR>*fwotadetect=?#<CR>	

Function	Type	Operation	ASCII
Baud Rate	Write	9600	<CR>*baud=9600#<CR>
	Write	14400	<CR>*baud=14400#<CR>
	Write	19200	<CR>*baud=19200#<CR>
	Write	38400	<CR>*baud=38400#<CR>
	Write	57600	<CR>*baud=57600#<CR>
	Write	115200	<CR>*baud=115200#<CR>
	Read	Current Baud Rate	<CR>*baud=?#<CR>
Lamp Control	Read	Lamp	<CR>*ltim=?#<CR>
	Write	Normal mode	<CR>*lampm=lnor#<CR>
	Write	Eco mode	<CR>*lampm=eco#<CR>
	Write	SmartEco mode	<CR>*lampm=seco#<CR>
	Write	Custom mode	<CR>*lampm=custom#<CR>
	Write	Light level for custom mode	<CR>*lampcustom=value#<CR>
	Read	Light level status for custom mode	<CR>*lampcustom=?#<CR>
	Read	Lamp Mode Status	<CR>*lampm=?#<CR>
Miscellaneous Installation	Read	Model Name	<CR>*modelname=?#<CR>
	Read	System F/W Version	<CR>*sysfwversion=?#<CR>
	Read	Scaler F/W Version	<CR>*scalerfwversion=?#<CR>
	Read	LAN F/W Version	<CR>*lanfwversion=?#<CR>
	Read	MCU F/W Version	<CR>*mcutfwversion=?#<CR>
	Write	Blank On	<CR>*blank=on#<CR>
	Write	Blank Off	<CR>*blank=off#<CR>
	Read	Blank Status	<CR>*blank=?#<CR>
	Write	Freeze On	<CR>*freeze=on#<CR>
	Write	Freeze Off	<CR>*freeze=off#<CR>
	Read	Freeze Status	<CR>*freeze=?#<CR>
	Write	Menu On	<CR>*menu=on#<CR>
	Write	Menu Off	<CR>*menu=off#<CR>
	Read	Menu Status	<CR>*menu=?#<CR>
	Write	Up	<CR>*up#<CR>
	Write	Down	<CR>*down#<CR>
	Write	Right	<CR>*right#<CR>
	Write	Left	<CR>*left#<CR>
	Write	Enter	<CR>*enter#<CR>

Function	Type	Operation	ASCII
Miscellaneous Installation (continued)	Write	Back	<CR>*back#<CR>
	Write	Source Menu On	<CR>*sourmenu=on#<CR>
	Write	Source Menu Off	<CR>*sourmenu=off#<CR>
	Read	Source Menu Status	<CR>*sourmenu=?#<CR>
	Write	3D Sync Off	<CR>*3d=off#<CR>
	Write	3D Auto	<CR>*3d=auto#<CR>
	Write	3D Sync Top Bottom	<CR>*3d=tb#<CR>
	Write	3D Sync Frame Sequential	<CR>*3d=fs#<CR>
	Write	3D Frame packing	<CR>*3d=fp#<CR>
	Write	3D Side by side	<CR>*3d=sbs#<CR>
	Write	3D inverter disable	<CR>*3d=da#<CR>
	Write	3D inverter	<CR>*3d=iv#<CR>
	Read	3D Sync Status	<CR>*3d=?#<CR>
	Write	AMX Device Discovery-on	<CR>*amxdd=on#<CR>
	Write	AMX Device Discovery-off	<CR>*amxdd=off#<CR>
	Read	AMX Device Discovery Status	<CR>*amxdd=?#<CR>
	Read	Mac Address	<CR>*macaddr=?#<CR>
	Read	Serial Number	<CR>*serialnumber=?#<CR>
	Write	High Altitude mode on	<CR>*highaltitude=on#<CR>
	Write	High Altitude mode off	<CR>*highaltitude=off#<CR>
	Read	High Altitude mode status	<CR>*highaltitude=?#<CR>
	Write	Set Fast Mode on	<CR>*fastmode=on#<CR>
	Write	Set Fast Mode off	<CR>*fastmode=off#<CR>
	Read	Get Fast Mode status	<CR>*fastmode=?#<CR>
	Write	Set Blending Ready on	<CR>*blendingready=on#<CR>
	Write	Set Blending Ready off	<CR>*blendingready=off#<CR>
	Read	Get Blending Ready status	<CR>*blendingready=?#<CR>
	Write	Set Test Pattern	<CR>*testpattern=value#<CR>
	Read	Get Test Pattern status	<CR>*testpattern=?#<CR>
	Write	Background Settings - Black	<CR>*background=black#<CR>
	Write	Background Settings - Blue	<CR>*background=blue#<CR>
	Write	Background Settings - Purple	<CR>*background=purple#<CR>
Write	Background Settings - Gray	<CR>*background=gray#<CR>	

Function	Type	Operation	ASCII
Miscellaneous Installation (continued)	Read	Background Settings value	<CR>*background=?#<CR>
	Write	Splash Screen - BenQ	<CR>*splash=benq#<CR>
	Write	Splash Screen - Black	<CR>*splash=black#<CR>
	Write	Splash Screen - Blue	<CR>*splash=blue#<CR>
	Read	Splash Screen value	<CR>*splash=?#<CR>
	Read	Filter timer status	<CR>*fltrtmr=?#<CR>
	Write	Filter timer setup (10 hours/step)	Min: <CR>*fltrtmrstp=10#<CR> Max: <CR>*fltrtmrstp=500#<CR>
	Read	Filter timer setup status	<CR>* fltrtmrstp=?#<CR>
	Write	Filter timer count reset	<CR>* fltrtmrcnrst#<CR>
	Read	Filter timer count status	<CR>* fltrtmrcnrst=?#<CR>
	Write	Filter time-up notify OSD/RS-232 on	<CR>*fltrtmpntfyosd=on#<CR> <CR>*fltrtmpntfyrs-232=on#<CR>
	Write	Filter time-up notify OSD/RS-232 off	<CR>*fltrtmpntfyosd=off#<CR> <CR>*fltrtmpntfyrs-232=off#<CR>
	Read	Filter time-up notify status	<CR>*fltrtmpntfyosd=?#<CR> <CR>*fltrtmpntfyrs-232=?#<CR>
	Auto	Filter change notify	<CR>*fltrchgntfy#<CR>
Color Calibration (only for service)	Write	Set BenQ gamma value	<CR>*gamma=value#<CR>
	Read	Gamma value status	<CR>*gamma=?#<CR>
	Write	Set HDR Brightness value	<CR>*hdrbri=value#<CR>
	Read	Get HDR Brightness value	<CR>*hdrbri=?#<CR>
	Write	Red Gain +	<CR>*RGain=+#<CR>
	Write	Red Gain -	<CR>*RGain=-#<CR>
	Write	Set Red Gain value	<CR>*RGain=value#<CR>
	Read	Get Red Gain value	<CR>*RGain=?#<CR>
	Write	Green Gain +	<CR>*GGain=+#<CR>
	Write	Green Gain -	<CR>*GGain=-#<CR>
	Write	Set Green Gain value	<CR>*GGain=value#<CR>
	Read	Get Green Gain value	<CR>*GGain=?#<CR>
	Write	Blue Gain +	<CR>*BGain=+#<CR>
	Write	Blue Gain -	<CR>*BGain=-#<CR>
	Write	Set Blue Gain value	<CR>*BGain=value#<CR>
	Read	Get Blue Gain value	<CR>*BGain=?#<CR>
	Write	Red Offset +	<CR>*ROffset=+#<CR>
	Write	Red Offset -	<CR>*ROffset=-#<CR>
	Write	Set Red Offset value	<CR>*ROffset=value#<CR>

Function	Type	Operation	ASCII
Color Calibration (only for service) (continued)	Read	Get Red Offset value	<CR>*ROffset=?#<CR>
	Write	Green Offset +	<CR>*GOffset=+#<CR>
	Write	Green Offset -	<CR>*GOffset=-#<CR>
	Write	Set Green Offset value	<CR>*GOffset=value#<CR>
	Read	Get Green Offset value	<CR>*GOffset=?#<CR>
	Write	Blue Offset +	<CR>*BOffset=+#<CR>
	Write	Blue Offset -	<CR>*BOffset=-#<CR>
	Write	Set Blue Offset value	<CR>*BOffset=value#<CR>
	Read	Get Blue Offset value	<CR>*BOffset=?#<CR>
	Write	Primary Color	<CR>*primcr=value#<CR>
	Read	Primary Color Status	<CR>*primcr=?#<CR>
	Write	Hue +	<CR>*hue=+#<CR>
	Write	Hue -	<CR>*hue=-#<CR>
	Write	Set Hue value	<CR>*hue=value#<CR>
	Read	Get Hue value	<CR>*hue=?#<CR>
	Write	Saturation +	<CR>*saturation =+#<CR>
	Write	Saturation -	<CR>*saturation =-#<CR>
	Write	Set Saturation value	<CR>*saturation =value#<CR>
	Read	Get Saturation value	<CR>*saturation =?#<CR>
	Write	Gain +	<CR>*gain=+#<CR>
	Write	Gain -	<CR>*gain=-#<CR>
	Write	Set Gain value	<CR>*gain=value#<CR>
	Read	Get Gain value	<CR>*gain=?#<CR>
	Write	White Red Gain +	<CR>*WRGain=+#<CR>
	Write	White Red Gain -	<CR>*WRGain=-#<CR>
	Write	Set White Red Gain value	<CR>*WRGain=value#<CR>
	Read	Get White Red Gain value	<CR>*WRGain=?#<CR>
	Write	White Green Gain +	<CR>*WGGain=+#<CR>
	Write	White Green Gain -	<CR>*WGGain=-#<CR>
	Write	Set White Green Gain value	<CR>*WGGain=value#<CR>
	Read	Get White Green Gain value	<CR>*WGGain=?#<CR>
	Write	White Blue Gain +	<CR>*WBGain=+#<CR>
Write	White Blue Gain -	<CR>*WBGain=-#<CR>	
Write	Set White Blue Gain value	<CR>*WBGain=value#<CR>	
Read	Get White Blue Gain value	<CR>*WBGain=?#<CR>	