

SMART Board MX and MX Pro series interactive displays

USER GUIDE

SBID-MX255-V3 | SBID-MX265-V3 | SBID-MX275-V3 | SBID-MX286-V3
SBID-MX255-V3-PW | SBID-MX265-V3-PW | SBID-MX275-V3-PW | SBID-MX286-V3-PW
SBID-MX055-V3 | SBID-MX065-V3 | SBID-MX075-V3 | SBID-MX086-V3
SBID-MX055-V3-PW | SBID-MX065-V3-PW | SBID-MX075-V3-PW | SBID-MX086-V3-PW

SBID-MX255-V2-C | SBID-MX265-V2-C | SBID-MX275-V2-C | SBID-MX286-V2-C
SBID-MX255-V2-CPW | SBID-MX265-V2-CPW | SBID-MX275-V2-CPW | SBID-MX286-V2-CPW

SBID-MX255-V2 | SBID-MX265-V2 | SBID-MX275-V2 | SBID-MX286-V2
SBID-MX255-V2-PW | SBID-MX265-V2-PW | SBID-MX275-V2-PW | SBID-MX286-V2-PW

SBID-MX365 | SBID-MX375 | SBID-MX386 | SBID-MX265 | SBID-MX275 | SBID-MX286

IDX55-3 | IDX65-3 | IDX75-3 | IDX86-3 | IDX55-2 | IDX65-2 | IDX75-2 | IDX86-2

Was this document helpful?
smarttech.com/docfeedback/171554

SMART[®]



Learn more

This guide and other resources for SMART Board MX and MX Pro series interactive displays are available in the Support section of the SMART website (smarttech.com/support). Scan this QR code to view these resources on your mobile device.

Trademark notice

SMART Board, smarttech, the SMART logo and all SMART taglines are trademarks or registered trademarks of SMART Technologies ULC in the U.S. and/or other countries. All third-party product and company names may be trademarks of their respective owners.

Copyright notice

© 2021 SMART Technologies ULC. All rights reserved. No part of this publication may be reproduced, transmitted, transcribed, stored in a retrieval system or translated into any language in any form by any means without the prior written consent of SMART Technologies ULC. Information in this manual is subject to change without notice and does not represent a commitment on the part of SMART.

This product and/or use thereof is covered by one or more of the following U.S. patents:

www.smarttech.com/patents

December 15, 2021

Important information

NOTE

Refer to the *SMART Board MX and MX Pro series interactive displays installation and maintenance guide* (smarttech.com/kb/171555) for important information about installing and maintaining the display.

WARNING

- Do not open or disassemble the display. You risk electrical shock from the high voltage inside the casing. Opening the casing also voids the warranty.
- Do not stand (or allow children to stand) on a chair to touch the surface of the display.
- To reduce the risk of fire or electric shock, do not expose the display to rain or moisture.
- Do not insert objects inside the cabinet ventilation holes, because they could touch dangerous voltage points and cause electric shock, fire or product damage which may not be covered by the warranty.
- Do not place heavy objects on the power cable. Damage to the cable could cause shock, fire or product damage which may not be covered by the warranty.
- If the glass is broken, do not touch the liquid crystal. To prevent injury, handle glass fragments with care when disposing of them.
- Disconnect all of the display's power cables from the wall outlet and seek assistance from qualified service personnel if any of the following occur:
 - The power cable or plug is damaged
 - Liquid is spilled into the display
 - Objects fall into the display
 - The display is dropped
 - Structural damage, such as cracking, occurs
 - The display behaves unexpectedly when you follow operating instructions
- Before inserting or removing an OPS from the display, turn off the display using the switch at the back of the display. See [Open Pluggable Slot computer \(OPS\) disclaimer](#) for more information.

ENERGY STAR®



ENERGY STAR is the government-backed symbol for energy efficiency, providing simple, credible, and unbiased information that consumers and businesses rely on to make well-informed decisions. ENERGY STAR-certified products are the simple choice for energy efficiency, making it

easy for consumers and businesses to make purchases that save them money and protect the environment. The U.S. EPA ensures that each product that earns the label is independently certified to deliver the quality, performance, and savings that users have come to expect.

As shipped, your display delivers ENERGY STAR performance and savings. However, changing some settings may increase energy consumption beyond the limits required for ENERGY STAR certification. For example, increased brightness and contrast will increase power consumption.

Please consider the environment when you choose non-ENERGY STAR settings.

Federal Communication Commission interference statement

FCC

Suppliers Declaration of Conformity

47 CFR § 2.1077 Compliance Information

Unique Identifier: IDX55-2, IDX55-3, IDX65-1, IDX65-2, IDX-65-3, IDX75-1, IDX75-2, IDX75-3, IDX86-1, IDX86-2, IDX86-3

Responsible Party – U.S. Contact Information

SMART Technologies Inc.

2401 4th Ave., 3rd Floor

Seattle, WA 98121

compliance@smarttech.com

This device complies with Part 15 of the FCC Rules. Operation is subject to the following two conditions:

1. This device may not cause harmful interference, and
2. this device must accept any interference received, including interference that may cause undesired operation.

Important information

NOTE

This equipment has been tested and found to comply with the limits for a Class A digital device, pursuant to part 15 of the FCC Rules. These limits are designed to provide reasonable protection against harmful interference when the equipment is operated in a commercial environment. This equipment generates, uses, and can radiate radio frequency energy and, if not installed and used in accordance with the instruction manual, may cause harmful interference to radio communications. Operation of this equipment in a residential area is likely to cause harmful interference in which case the user will be required to correct the interference at his own expense.

CAUTION

Any changes or modifications not expressly approved by the party responsible for compliance could void the user's authority to operate this equipment.

Restriction

Operations in the 5.15-5.25GHz band are restricted to indoor usage only.

IEEE 802.11b or 802.11g operation of this product in the USA is firmware limited to channels 1 through 13.

CAUTION

- i. the device for operation in the band 5150-5250 MHz is only for indoor use to reduce the potential for harmful interference to co-channel mobile satellite systems;
- ii. the maximum antenna gain permitted for devices in the bands 5250-5350 MHz and 5470-5725 MHz shall comply with the e.i.r.p. limit; and
- iii. the maximum antenna gain permitted for devices in the band 5725-5825 MHz shall comply with the e.i.r.p. limits specified for point-to-point and non point-to-point operation as appropriate.
- iv. Users should also be advised that high-power radars are allocated as primary users (i.e., priority users) of the bands 5250-5350 MHz and 5650-5850 MHz and that these radars could cause interference and/or damage to LE-LAN devices.

Radiation exposure statement

This equipment complies with FCC radiation exposure limits set forth for an uncontrolled environment. This equipment should be installed and operated with minimum distance of 20 cm between the antenna of this device and all nearby persons. This transmitter must not be co-located or operated in conjunction with any other antenna or transmitter.

Innovation, Science and Economic Development Canada statement

This device complies with RSS-247 of the Innovation, Science and Economic Development Canada Rules. Operation is subject to the following two conditions:

1. This device may not cause harmful interference, and
2. this device must accept any interference received, including interference that may cause undesired operation.

Radiation exposure statement

This equipment complies with ISED radiation exposure limits set forth for an uncontrolled environment. This equipment should be installed and operated with minimum distance of 20 cm between the antenna of this device and all nearby persons. This transmitter must not be co-located or operated in conjunction with any other antenna or transmitter.

Innovation, Science et Développement économique Déclaration du Canada

Cet appareil est conforme à la norme ISED CNR-247 pour les appareils radio agréés. Son fonctionnement est soumis aux deux conditions suivantes:

1. le dispositif ne doit pas produire de brouillage préjudiciable, et
2. ce dispositif doit accepter tout brouillage reçu, y compris un brouillage susceptible de provoquer un fonctionnement indésirable.

AVERTISSEMENT

- i. les dispositifs fonctionnant dans la bande 5 150-5 250 MHz sont réservés uniquement pour une utilisation à l'intérieur afin de réduire les risques de brouillage préjudiciable aux systèmes de satellites mobiles utilisant les mêmes canaux;
- ii. le gain maximal d'antenne permis pour les dispositifs utilisant les bandes 5 250-5 350 MHz et 5 470-5 725 MHz doit se conformer à la limite de p.i.r.e.;
- iii. le gain maximal d'antenne permis (pour les dispositifs utilisant la bande 5 725-5 825 MHz) doit se conformer à la limite de p.i.r.e. spécifiée pour l'exploitation point à point et non point à point, selon le cas.
- iv. De plus, les utilisateurs devraient aussi être avisés que les utilisateurs de radars de haute puissance sont désignés utilisateurs principaux (c.-à-d., qu'ils ont la priorité) pour les bandes 5 250-5 350 MHz et 5 650-5 850 MHz et que ces radars pourraient causer du brouillage et/ou des dommages aux dispositifs LAN-EL.

Important information

Déclaration d'exposition aux radiations

Cet équipement est conforme aux limites d'exposition aux rayonnements ISED établies pour un environnement non contrôlé. Cet équipement doit être installé et utilisé avec un minimum de 20 cm de distance entre la source de rayonnement et votre corps. Cet émetteur ne doit pas être co-implantés ou exploités conjointement avec une autre antenne ou émetteur.

EU declaration of conformity

Hereby SMART Technologies ULC declares that the radio equipment type Interactive displays model IDX55-2, IDX55-3, IDX65-1, IDX65-2, IDX-65-3, IDX75-1, IDX75-2, IDX75-3, IDX86-1, IDX86-2, IDX86-3, and the OPS AM40, AM50 are in compliance with Directive 2014/53/EU.



WARNING

Operation of this equipment in a residential environment this equipment may could cause radio interference.

The full text of the EU declaration of conformity is available at the following internet address: smarttech.com/compliance

The frequency band and the maximum transmitted power in EU are listed below:

Transmitting Band (MHz)	Maximum Transmit Power EIRP (dBm)
2402-2483.5	19
5150-5350	23
5470-5725	23

Restrictions in

AT/BE/BG/CZ/DK/EE/FR/DE/IS/IE/IT/EL/ES/CY/LV/LI/LT/LU/HU/M
TNL/NO/PL/PT/RO/SI/SK/TR/FI/SE/CH/UK/HR—5150MHz-
5350MHZ is for indoor use only



CAUTION: EXPOSURE TO RADIO FREQUENCY RADIATION

This equipment complies with EU radiation exposure limits set forth for an uncontrolled environment. This equipment should be installed and operated with minimum distance 20 cm between the radiator and your body.

Contents

- Important information 3**
- Chapter 1: Welcome 8**
 - About this guide 8
 - About the display 8
 - Identifying your specific model 13
 - Accessories 13
 - More information 15
- Chapter 2: Using basic features 16**
 - Waking up the display and putting it back to sleep 16
 - Using the Home button 17
 - Using the front control panel 17
 - Using the remote control 18
 - Using touch 21
 - Writing, drawing, and erasing 23
 - Adjusting the volume 24
 - Freezing or hiding the screen 25
- Chapter 3: Using the iQ apps 26**
 - Using the Apps Library 26
 - Using the Files Library 27
 - Using SMART Whiteboard 27
 - Using Browser 27
 - Using Screen Share 27
 - Using SMART Mirror 28
 - Using Input 28
 - Using screenshots 28
 - Installing third-party apps 28
 - Cleaning up the display 29
 - Using kapp Whiteboard 29
- Chapter 4: Connecting computers and other devices 30**
 - Installing and using SMART software 30
 - Connecting room computers and guest laptops 33
 - Connecting a SMART OPS PC module 40
 - Connecting USB drives, peripherals, and other devices 40

- Chapter 5: Troubleshooting 42**
- The display isn't turning on 42
- The screen is blank or there's a problem with the image on the screen 43
- There's no sound or there's a problem with the sound 45
- Touch isn't working as expected 46
- The pens and erasers aren't working as expected 47
- iQ apps aren't working as expected 47
- SMART software on connected computers isn't working as expected 48
- The SMART OPS PC module isn't working as expected 48
- The Intel Compute Card isn't working as expected 48
- Contacting your reseller for additional support 48

Chapter 1

Welcome

About this guide	8
About the display	8
Touch	9
Writing, drawing, and erasing	9
iQ experience	10
Display	10
Audio	10
Network connectivity	10
Room computers and guest laptops	11
Accessory slot	11
Front control panel	11
Front connector panel	12
Ambient light sensor	12
Power status light	12
Remote control and IR sensor	12
Identifying your specific model	13
Accessories	13
SMART OPS PC module	14
Stands	14
USB extenders	14
More information	15

This chapter introduces the SMART Board® MX and MX Pro series interactive displays.

About this guide

This guide explains how to use a SMART Board MX or MX Pro series interactive display.

This guide is intended for individuals who use displays in their organizations. Other documentation and resources are available for those who install and maintain displays (see *More information* on page 15).

About the display

The SMART Board MX or MX Pro interactive display with iQ is the hub of your classroom.

The display includes an extensive set of features and components:

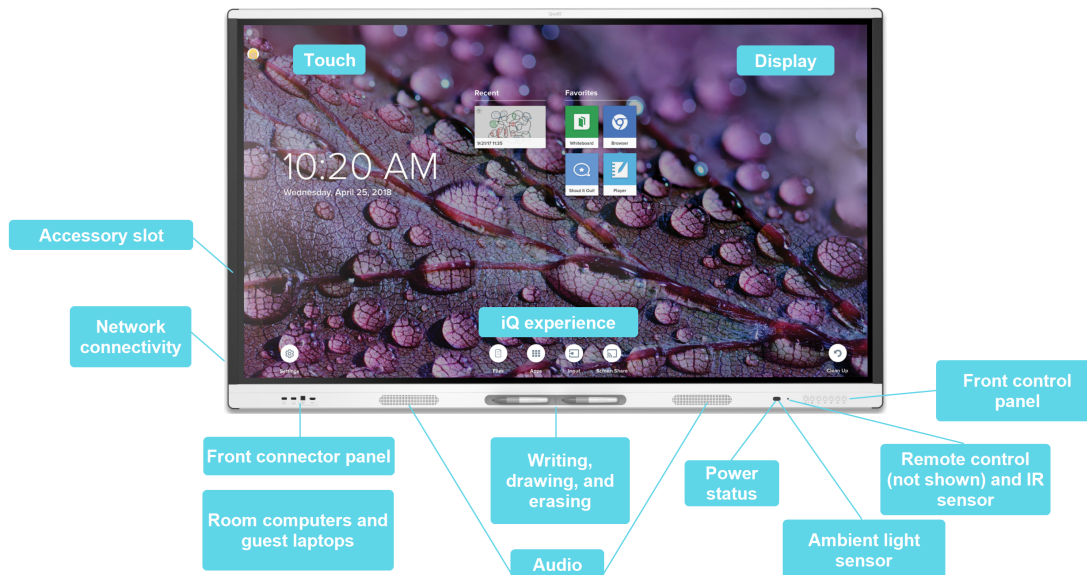

Touch

You can do everything on the display that you can do at your computer—open and close applications, meet with others, create new documents or edit existing ones, visit websites, play and manipulate videos, and so on—by touching the display’s surface.

You can use an array of gestures within applications, including panning, scaling, rotating, and zooming in and out.

For more information, see *Using touch* on page 21.

Writing, drawing, and erasing

The display comes with two pens, which you can use to write or draw on the screen.

Use your fist or palm to erase digital ink on the screen.

With Object Awareness™, the display responds automatically to the tool or object you’re using, whether it’s a pen, finger, or palm. The display’s Simultaneous Tool Differentiation technologies allow two people to write independently and simultaneously.

For more information, see *Writing, drawing, and erasing* on page 23.

iQ experience

The display's iQ experience provides one-touch access to collaborative tools, including a whiteboard, wireless screen sharing, and a web browser. With minimal network integration, there's no need for wires, cables, or manual software and firmware updates.

From the iQ experience Home screen, you can open the iQ apps, switch inputs, and adjust settings.

For more information about the Home screen, see *Using the Home button* on page 17.

For more information about the iQ apps, see *Chapter 3: Using the iQ apps* on page 26.

Display

The 4K ultra-high-definition LCD display provides optimal image clarity and wide viewing angles.

The size of the display varies by model:

Models	Size (diagonal)
SBID-MX255-V3 / SBID-MX255-V2-C / SBID-MX255-V2-CPW / SBID-MX255-V2 / SBID-MX255-V2-PW	55"
SBID-MX265-V3 / SBID-MX265-V2-C / SBID-MX265-V2-CPW / SBID-MX265-V2 / SBID-MX265-V2-PW / SBID-MX365 / SBID-MX265	65"
SBID-MX275-V3 / SBID-MX275-V2-C / SBID-MX275-V2-CPW / SBID-MX275-V2 / SBID-MX275-V2-PW / SBID-MX375 / SBID-MX275	75"
SBID-MX286-V3 / SBID-MX286-V2-C / SBID-MX286-V2-CPW / SBID-MX286-V2 / SBID-MX286-V2-PW / SBID-MX386 / SBID-MX286	86"

Audio

The display includes two integrated speakers, which are designed to provide sound at the front of a room.

Network connectivity

The display requires a network connection for downloading software and firmware updates, and a number of the iQ apps require a network connection as well.

You can connect to a network using Wi-Fi or the RJ45 LAN jack on the display:

- Wi-Fi supports both 2.4 and 5 GHz bands.
- The two RJ45 jacks allow you to connect the display and an external device, such as a computer, to a Ethernet network.

Room computers and guest laptops

You can connect room computers and guest laptops and use the display to view and interact with them.

The display comes with SMART software that you can install on connected computers to take full advantage of the display's features while using the connected computers.

For more information, see *Chapter 4: Connecting computers and other devices* on page 30.

Accessory slot

The iQ appliance is inserted in the accessory slot on the back of the following models:

- SBID-MX365
- SBID-MX375
- SBID-MX386
- SBID-MX265
- SBID-MX275
- SBID-MX286

NOTE

With the SBID-MX365, SBID-MX375, and SBID-MX386 models, you can insert an Intel Compute Card in the appliance to provide a complete Windows 10 solution at your fingertips, without the need for an external PC or cables.

For other models, you can install an OPS-compatible device, such as a SMART OPS PC module, in the accessory slot. SMART OPS PC modules provide a complete Windows® 10 Pro installation.

For more information on SMART OPS PC modules, see *SMART OPS PC module* on page 14.

CAUTION

The accessory slot's maximum available power is 60 W. The slot is not a limited power source. To reduce the risk of fire, make sure that accessories connecting to the slot satisfy the fire enclosure requirements of IEC 62368-1.

Front control panel

The front control panel contains buttons for turning the display on and off, controlling the volume, freezing and unfreezing the screen, and showing and hiding a screen shade.

For more information about the front control panel, see *Using the front control panel* on page 17.

Front connector panel

The front connector panel includes connectors for USB peripherals and a computer or other input source.

For more information about the convenience panel, see *Connecting room computers and guest laptops* on page 33.

Ambient light sensor

The ambient light sensor is located in the bottom-right corner of the display's frame.

The ambient light sensor detects the brightness of the room and adjusts the screen's brightness accordingly.

Power status light

The power status is located in the bottom-right corner of the display's frame.

The power status light indicates the display's status.

Power status light	Display status
Red	Standby mode
Green	Normal operating mode

Remote control and IR sensor

You can use the remote control to turn the display on and off, adjust display settings, and so on.

The IR sensor for the remote control is located in the bottom-right corner of the display's frame.

For more information about the remote control, see *Using the remote control* on page 18.

Identifying your specific model

There are several series of SMART Board MX and MX Pro series interactive displays:

SMART Board MX (V3) series	SMART Board MX (V2-C) series	SMART Board MX (V2) series	SMART MX series
SBID-MX255-V3	SBID-MX255-V2-C	SBID-MX255-V2	SBID-MX365
SBID-MX265-V3	SBID-MX265-V2-C	SBID-MX265-V2	SBID-MX375
SBID-MX275-V3	SBID-MX275-V2-C	SBID-MX275-V2	SBID-MX386
SBID-MX286-V3	SBID-MX286-V2-C	SBID-MX286-V2	SBID-MX265
SBID-MX255-V3-PW	SBID-MX255-V2-CPW	SBID-MX255-V2-PW	SBID-MX275
SBID-MX265-V3-PW	SBID-MX265-V2-CPW	SBID-MX265-V2-PW	SBID-MX286
SBID-MX275-V3-PW	SBID-MX275-V2-CPW	SBID-MX275-V2-PW	
SBID-MX286-V3-PW	SBID-MX286-V2-CPW	SBID-MX286-V2-PW	

TIP

For help identifying your SMART Board MX (V2, V2-C, or V3) series model, see the label on the left side of the display.

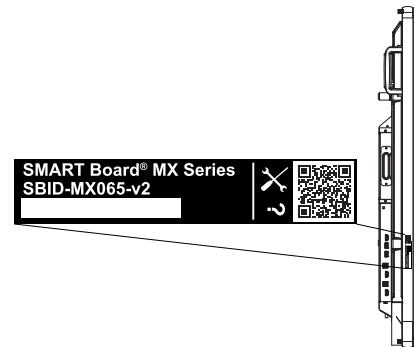

Accessories

Accessories for the display include:

- SMART OPS PC module
- Stands
- USB extenders

NOTE

For more information about these and other accessories, see smarttech.com/accessories.

SMART OPS PC module

SMART Open Pluggable Specification (OPS) PC modules provide a hassle-free Windows Pro installation based on Intel® Core™ processors and are designed specifically to work with a SMART display. All OPS PC modules are WHQL certified and fully licensed with Windows Pro. Install the OPS PC module in a display's accessory slot to provide a complete 4K UHD Windows installation at your fingertips, without the need for an external PC or additional cables.

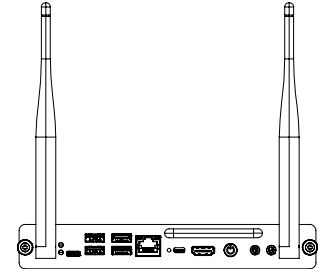

Install familiar Windows applications, such as SMART Notebook®, SMART TeamWorks™, and SMART Meeting Pro® software, and access the internet directly through your display's network connection. Upgrades and service for the OPS PC module are easy to perform without removing the display from its mounting.

Stands

If you want to move the display from place to place, you can install it on a SMART mobile stand. If you are installing the display on a wall that cannot support the display's full weight, you can install the display on a SMART floor stand.

USB extenders

As noted in the display's specifications, there is a maximum length for USB cable connections between the display and computer.

When using USB 2.0, the cable should be no longer than 16' (5 m).

When using USB 3.0, the cable should be no longer than 9' (3 m).

Use one of the following USB extenders if you need a longer USB connection:

Extender	Specifications
USB-XT	smarttech.com/kb/119318

NOTES

- To extend touch using the SMART CAT 5 USB extender (CAT5-XT-1100) use a touch USB connector associated with an HDMI 1, HDMI 2, or VGA input. The extender will not function correctly if used to extend touch associated with the HDMI 3 input on the front of the display.
 - For more information about extending USB connections, see [USB cable extenders](#).
-

More information

In addition to this guide, SMART provides other documents for the display in the Support section of the SMART website (smarttech.com/support). Scan the QR code on the cover of this guide to view links to SMART Board MX and MX Pro series interactive display documents and other support resources.

Chapter 2

Using basic features

Waking up the display and putting it back to sleep	16
Using the Home button	17
Using the front control panel	17
Using the remote control	18
SMART Board MX (V3, V2 and V2-C) series	19
SMART Board MX series	20
Using touch	21
Writing, drawing, and erasing	23
Writing and drawing in digital ink	23
Using the SMART Ink dynamic (floating) toolbar	23
Changing a pen's default color, thickness, and other properties	24
Erasing digital ink	24
Adjusting the volume	24
Freezing or hiding the screen	25
Freezing the screen	25
Showing and hiding the screen shade	25

This chapter explains how to wake the display when it's asleep, how to view connected computers' input and how to interact with the display.

Waking up the display and putting it back to sleep

To wake the display, press the **Power** button  on the front control panel or remote control.

To return the display to a partial sleeping state, press the **Power** button  on the front control panel or remote control.

NOTE

Touch is not available right after waking up the display or turning it on. Wait a few seconds and then the display will respond to touch.

For information about turning the display off, see *SMART Board MX and MX Pro series interactive displays installation and maintenance guide* (smarttech.com/kb/171555).

Using the Home button

You can use the Home screen to open and use iQ apps, view the input of connected computers, and more. You can also change the background and personalize other features of the Home screen. To learn more about the Home screen, see [Understanding the Home screen](#).

The Input screen shows thumbnails of connected computers and allows you to switch among inputs.

You can return to the Home screen or the Input screen at any time by following the instructions below.

To show the Home screen or the Input screen on SMART Board MX (V3, V2 and V2-C) series displays

Tap the **Home** button  on the front control panel.

OR

Press the **Home** button  on the remote control.

To show the Home screen or the Input screen on SMART Board MX series displays

Tap  at the bottom of the screen.

Using the front control panel

Depending on the model, the front control panel contains buttons for returning to the iQ Home screen, switching the input source, showing and hiding a screen shade, controlling the volume, freezing and unfreezing the screen, and turning the display on and off.

SMART Board MX (V3, V2 and V2-C) series

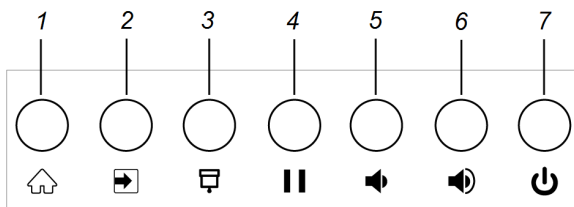

SMART Board MX series

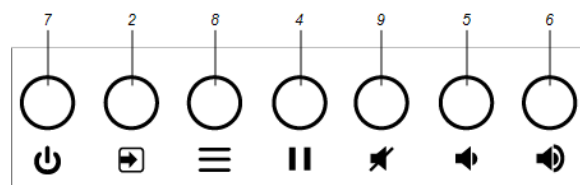

No.	Name	Procedure
1	Home	Press to return to the iQ Home screen (see <i>Using the Home button</i> above).
2	Input select	Press to switch input source (see <i>Viewing a connected computer's input</i> on page 37).

No.	Name	Procedure
3	Screen shade	Press to hide screen contents behind a screen shade (see <i>Freezing or hiding the screen</i> on page 25).
4	Freeze	Press to freeze and unfreeze the screen (see <i>Freezing the screen</i> on page 25).
5	Volume decrease	Press to turn down the volume (see <i>Adjusting the volume</i> on page 24).
6	Volume increase	Press to turn up the volume (see <i>Adjusting the volume</i> on page 24).
7	Power	Press to wake the display (see <i>Waking up the display and putting it back to sleep</i> on page 16). Press again to enter Sleep mode (see <i>Waking up the display and putting it back to sleep</i> on page 16).
8	Menu	Press to open the display's settings.
9	Mute	Press to mute or unmute the volume.

Using the remote control

The display comes with one of two infrared remote control models. These models are similar, except one has a screen sharing button.

Use the infrared remote control to turn the display on or off, change the input source, change the volume, access the display's iQ apps, and more. You can also use the remote control to open the on-screen menus and change the display's settings.

IMPORTANT

- Do not subject the remote control to strong shock.
 - Keep the remote control away from liquids. If it gets wet, wipe it dry immediately.
 - Do not expose the remote control to heat or steam.
 - Do not open any part of the remote control other than the battery compartment.
-

SMART Board MX (V3, V2 and V2-C) series

The image and table below list the remote control's functions.

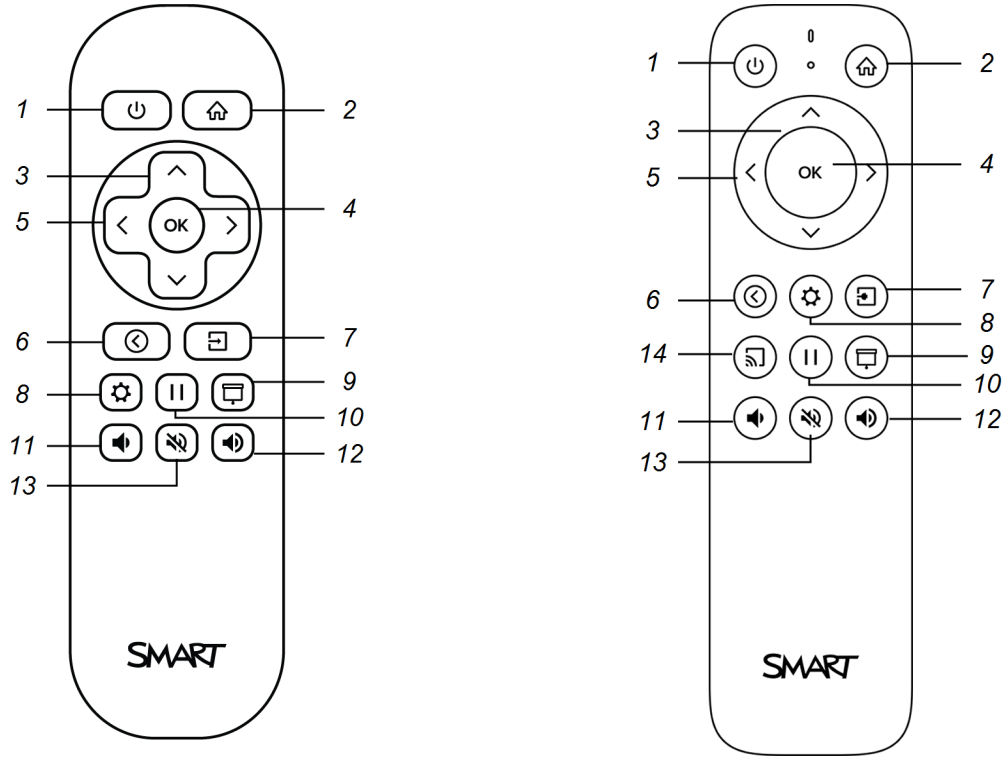

No.	Name	Procedure
1	Power	<ul style="list-style-type: none"> Press to enter or exit Standby mode (see <i>Waking up the display and putting it back to sleep</i> on page 16). <p>NOTE</p> <p>Touch is not available right after waking up the display or turning it on. Wait a few seconds and then the display will respond to touch.</p> <ul style="list-style-type: none"> Press and hold for four seconds to turn off the display.
2	Home	Open the iQ Home screen (see <i>Using the Home button</i> on page 17).
3	Up and down buttons	Select a menu option in the settings.
4	OK	Select menu option in the settings.
5	Left and right buttons	Change the value of the selected setting.

No.	Name	Procedure
6	Back	Go one step back in the navigation history.
7	Input	Switch input sources (see <i>Viewing a connected computer's input</i> on page 37).
8	Settings	Open display settings.
9	Screen shade	Hide screen contents behind a screen shade (see <i>Showing and hiding the screen shade</i> on page 25).
10	Freeze frame	Freeze and unfreeze the screen (see page 25).
11	Volume increase	Increase the volume (see <i>Adjusting the volume</i> on page 24).
12	Volume decrease	Decrease the volume (see <i>Adjusting the volume</i> on page 24).
13	Volume mute	Mute the volume (see <i>Adjusting the volume</i> on page 24).
14	Share screen	Open the Screen Share app (see Sharing your device's screen to the display).

NOTE

This button is not available on all remote control models.

SMART Board MX series

The image and table below list the remote control's functions.

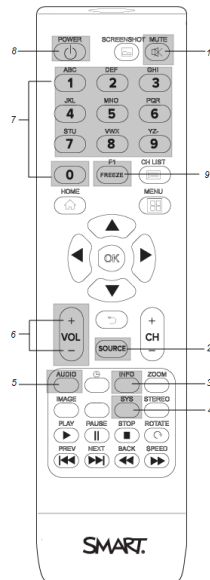

No.	Name	Function
1	MUTE	Mute or unmute the volume
2	SOURCE	Open the input source menu
3	INFO	Press to show the display's detected resolution and refresh rate for the current input source
4	SYS	Open the display's settings
5	AUDIO	Change the display's audio mode
6	VOL + / VOL -	Increase or decrease volume
7	[Number buttons]	Press buttons on the number pad to customize settings
8	POWER	Wake the display. Enter Sleep mode.
9	FREEZE	Freezes the screen. NOTE Freezing the screen does not pause any applications running on the connected computer. It simply freezes the display of those applications.

NOTE

The buttons listed in this table and highlighted in gray in the image above are the only ones that have an effect on the display. Pressing the other buttons will make the remote control sensor flash, but they have no effect.

Using touch

You can do everything on the display that you can do at your computer—open and close applications, meet with others, create new documents or edit existing ones, visit websites, play and manipulate videos, and so on—by touching the display's surface.

You can use a variety of gestures within applications, including panning, scaling, rotating, and zooming in and out.

The display's support for up to 20 simultaneous interaction points enables you and other users to interact with objects on the screen at the same time.

NOTE

Not all gestures work in all applications. Refer to an application's documentation to learn which gestures it supports.

Pan (one finger)

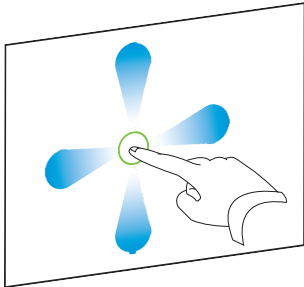

Pan (two fingers) / scroll

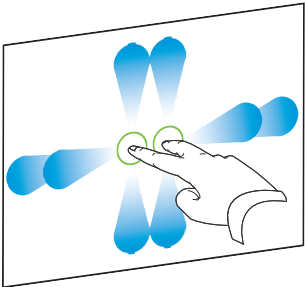

Pinch to zoom in / scale (enlarge)

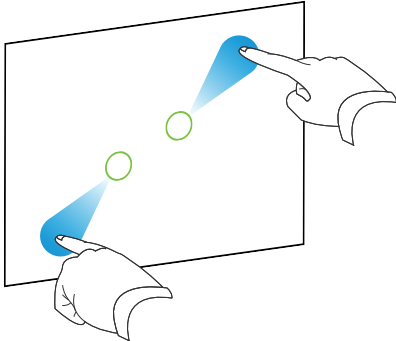

Pinch to zoom out / scale (reduce)

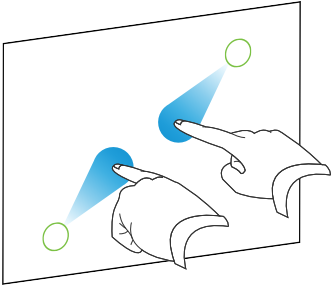

Rotate

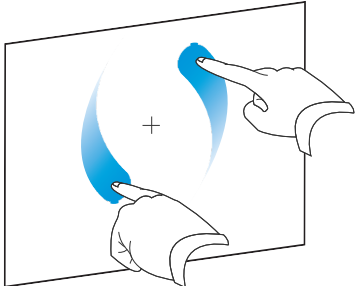

Flick

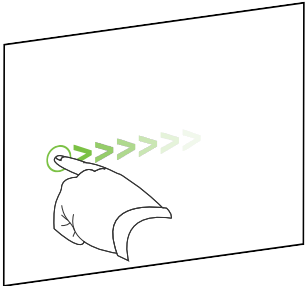

Erase with palm

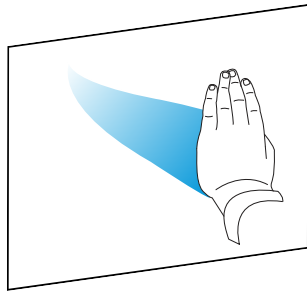

Erase with fist

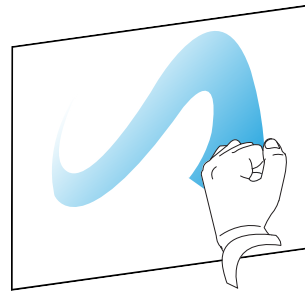

Writing, drawing, and erasing

The display includes two pens, which you can use to write or draw in digital ink. You can erase digital ink using gestures or the eraser tool in the apps.

Writing and drawing in digital ink

To write or draw in digital ink

1. Pick up one of the display's pens.
2. Use the pen to write or draw in digital ink.

Using the SMART Ink® dynamic (floating) toolbar

When you start drawing on the screen while viewing a connected computer's input, the SMART Ink® dynamic (floating) toolbar for SMART Ink appears on the screen. You can use this toolbar to temporarily change the pen's color, thickness, or other properties, and you can also access SMART Ink's tools, such as screen capture, spotlight, screen shade, and so on.

To learn more about SMART Ink and its toolbar, visit the [SMART Ink support page](#). Here are a few quick links to get you started:

- [Turning SMART Ink on or off](#)
- [Opening the dynamic \(floating\) toolbar](#)
- [Closing \(hiding\) the toolbar](#)
- [Using SMART Ink presentation tools](#)



Changing a pen's default color, thickness, and other properties

You can change a pen's color, thickness, and other properties temporarily using the SMART Ink dynamic (floating) toolbar when you're viewing a connected computer's input.

To change the pen's default color, thickness, and other properties, see [Changing pen, eraser, and button settings](#).

Erasing digital ink

You can erase digital ink from the screen using your palm or fist:

To erase digital ink

Move your fist or palm over the digital ink you want to erase.



Adjusting the volume

Use the buttons on the front control panel or the remote control to increase, decrease, or mute the display's volume.



NOTE

See *There's no sound or there's a problem with the sound* on page 45 if you encounter issues with the display's sound.

To turn the volume up or down

Press the **Volume Up**  or **Volume Down**  button on the front control panel or the remote control.

NOTES

- Press and hold the **Volume Down**  button to rapidly decrease the volume.
 - When you press the **Volume Up**  or **Volume Down**  button on the front control panel or the remote control, you can use the on-screen slider to adjust the volume.
-

To mute the volume

Press the remote control's **Mute**  button.

Freezing or hiding the screen

You can temporarily freeze or hide the contents on the screen using the display's freeze and screen shade features.

Freezing the screen

You can temporarily freeze the screen by pressing the **Freeze**  button on the front control panel or remote control. This is particularly useful when you want to pause a video, an animation, or other moving images.

NOTE

Freezing the screen does not pause applications that are running on the connected computer. It simply freezes the display of those applications.

TIP

You can write or draw over the screen while it is frozen (see *Writing, drawing, and erasing* on page 23). If the iQ experience is enabled, you can then save the screenshot of your writing or drawing to the Files Library (see [Using the iQ experience Files Library](#)).

To unfreeze the screen, press the **Freeze**  button again.

Showing and hiding the screen shade



For SMART Board MX (V3), MX (V3) Pro, MX (V2-C), MX (V2-C) Pro, MX (V2), MX (V2) Pro, and MX Pro series displays.

You can temporarily hide the contents of the screen behind a virtual screen shade by pressing the **Screen Shade**  button on the front control panel or remote control.

To remove the screen shade and reveal the screen contents, press the **Screen Shade**  button again.

Chapter 3

Using the iQ apps

The display comes with the following iQ apps:

- SMART Whiteboard
- Browser
- Input
- Screen Share
- kapp Whiteboard

You can use these apps along with the Files Library and Apps Library to deliver lessons in a classroom or coordinate meetings and other collaborative activities.

NOTE

Some apps, such as Screen Share, require a properly configured network connection. If you're experiencing issues with these apps, contact your IT administrator to make sure the network and display have been properly configured.

Using the Apps Library

The Apps Library contains the Browser, SMART Whiteboard, and kapp Whiteboard apps. You can also add apps from the web and SMART's app store or install third-party apps.

To open the Apps Library

From the Home screen, tap **Apps Library** .

To learn how to use the other features of Apps Library, see [Adding and managing apps in the iQ experience](#).

Using the Files Library

The Files Library contains kapp Whiteboard sessions, SMART Notebook files, SMART Whiteboards, PDFs, and screenshots. If a USB drive is connected to the display, the files on the USB drive are also available in the Files Library. Although these files can be viewed on the display, they are not saved on the display.

To open Files Library

From the Home screen, tap **Files Library** .

To learn how to use the other features of Files Library, see [Using the iQ experience Files Library](#).

Using SMART Whiteboard

Use SMART Whiteboard to open, view, and interact with SMART Notebook software files and whiteboards. SMART Whiteboard makes it easy to present SMART Notebook files and play SMART lab™ activities on the display.

To learn more about SMART Whiteboard, see [Using SMART Whiteboard on your display](#).

Using Browser

You can use Browser to view web sites on the display.

To learn more about Browser, see [Browsing the internet on your display](#).

Using Screen Share

 **For SMART Board MX (V2-C), MX (V2-C) Pro, MX (V2), MX (V2) Pro, and MX series displays.**

You can share the screens from computers and mobile devices on the display wirelessly using Screen Share.

Screen Share supports:

- Chromebook™ laptops, using the Chrome™ browser
- Windows computers, using Miracast¹, Chrome browser, or AirParrot

¹Windows 10 operating system only

- Mac computers and iOS devices, using AirPlay
- Android™ devices, using Cast Screen

You can also download the SMART Screen Share app for Chromebooks, Windows computers, Mac computers, iOS devices, and Android devices.

To learn how to use the other features of Screen Share, see [Sharing your device's screen to the display](#).

Using SMART Mirror

 **For SMART Board MX (V3) and MX (V3) Pro series displays**

Use SMART Mirror to share content via the internet. No apps are needed to share your screen from Android, Chrome, OS, IOS, macOS, or Windows devices.

To learn how to connect to the SMART Mirror from devices and collaborate on content, see [Using SMART Mirror](#).

Using Input

You can use the connectors the display to connect a room computer, guest laptops, and other input sources.

To learn how to connect computers to the display and view their video output, see [Viewing a connected computer's screen](#).

Using screenshots

When using the Browser or Screen Share apps, you can write or draw on a screenshot and save it to the Files Library.

To learn more about screenshots, see [Writing and drawing over content and saving as screenshots in the iQ experience](#).

Installing third-party apps

You can install third-party apps from the Google Play Store using SMART Remote Management.

To learn more about installing third-party apps, see [Adding and managing apps in the iQ experience](#).

Cleaning up the display

After you've finished using the display, tap **Clean Up**  on the Home screen to clean up the display for the next user.

Tapping the **Clean Up** button does the following:

- Signs out of everything in the Browser app.
- Closes all applications, including third-party apps.

NOTE

Tapping **Clean Up** doesn't perform a factory reset on the display.

To learn more, see [About the iQ experience and navigating the Home screen](#).

Using kapp Whiteboard

 For SMART Board MX (V2-C), MX (V2-C) Pro, MX (V2), MX (V2) Pro, and MX series displays.

Use the kapp Whiteboard to write and erase notes on the display just as you do on a traditional dry erase board. You can also save your notes for later and share them using the SMART kapp® app. The kapp Whiteboard app is the default whiteboard for enterprise models.

To learn how to write, draw, and erase in kapp Whiteboard, see *Writing, drawing, and erasing* on page 23.

To learn how to use the other features of kapp Whiteboard, see [Using the kapp Whiteboard](#).

Chapter 4

Connecting computers and other devices

Installing and using SMART software	30
Downloading and installing SMART software	31
Using SMART software	31
Connecting room computers and guest laptops	33
Viewing a connected computer's input	37
Setting a connected computer's resolution and refresh rate	38
Connecting USB drives, peripherals, and other devices	39
Troubleshooting connected computers	39
Connecting a SMART OPS PC module	40
Connecting USB drives, peripherals, and other devices	40

WARNING

Ensure that any cables that cross the floor to the display are properly bundled and marked to avoid a trip hazard.

Installing and using SMART software

The display comes with the following software, which you can install on connected computers:

Software	Description	Notes
SMART Learning Suite	A suite of desktop and online software that combines lesson delivery, activities, assessments, and collaborative workspaces. Includes SMART Notebook software and Lumio™ by SMART.	Education models only. SMART Notebook basic version also available.
SMART Meeting Pro	Software that enables you to capture ideas in a virtually unlimited interactive workspace.	Pro models only.
SMART Product Drivers	Software that enables the computer to detect input from the display.	Included with SMART Learning Suite

Software	Description	Notes
SMART Ink	Software that enables you to write and draw in digital ink over applications, files, folders, websites, and any other open window.	Included with SMART Learning Suite

TIP

You can purchase additional licenses or subscriptions to SMART software to install on other computers.

The following software is also available but sold separately:

Software	Description	Licensing details
SMART TeamWorks Room	Software that simplifies meetings and facilitates deeper, more natural interaction with on-site and remote participants.	1-year subscription ¹
SMART Remote Management	Cloud-based mobile device management software for remotely maintaining, supporting, controlling, and securing the display and your other devices	3-year subscription ²

Contact your authorized SMART reseller (smarttech.com/where) for information about purchasing SMART software.

Downloading and installing SMART software

You can download SMART software from smarttech.com/downloads and install it following the instructions in [Installing and maintaining SMART Notebook](#), [Installing SMART TeamWorks](#), or [Installing and maintaining SMART Meeting Pro](#).

Using SMART software

For information about using SMART software, see the following pages in the Support section of the SMART website:

- [SMART Notebook](#)
- [Lumio by SMART](#)
- [SMART Learning Suite](#)
- [SMART TeamWorks](#)
- [SMART Meeting Pro](#)

¹Pro models only.

²Subscription terms may vary in some regions.

- [SMART Product Drivers and SMART Ink](#)
- [SMART Remote Management](#)

SMART Product Drivers and Ink are installed and used on the computer input of the display to enable touch and digital inking features. This supporting software is included with SMART's software products, such as [SMART Notebook](#), [SMART Meeting Pro](#), and [SMART TeamWorks](#), or is available for free download on support.smarttech.com/downloads/product-drivers.

SMART Product Drivers and Ink software have a number of features you can use to customize default settings for your display and troubleshoot common issues:

- [Adjust touch, mouse, and gesture settings.](#)
- [Calibrate the display to ensure touch behaves as expected.](#)
- [Turn SMART Ink on or off.](#)
- [Use SMART Ink in Microsoft Office products.](#)

Connecting room computers and guest laptops

You can connect room computers and guest laptops to the display and view and interact with their inputs.

- SMART Board MX (V3) series

Side and bottom connector panels

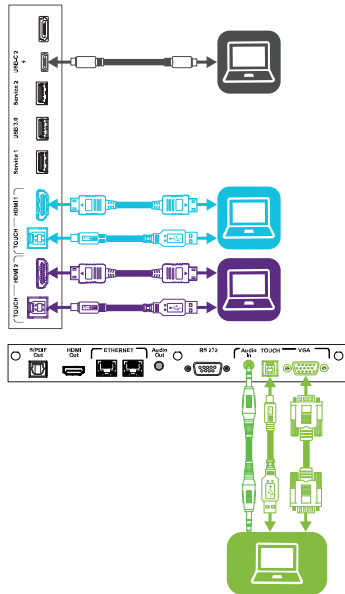

Front connector panel

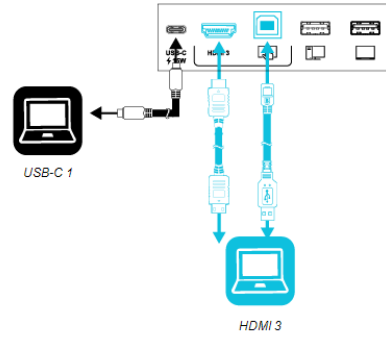

- SMART Board MX (V2-C) series

Side and bottom connector panels

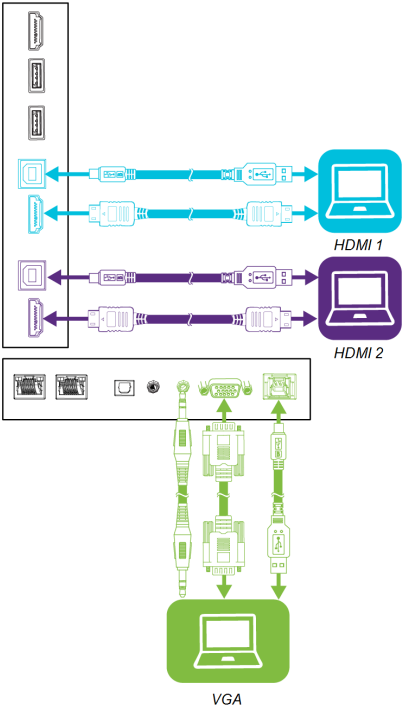

Front connector panel

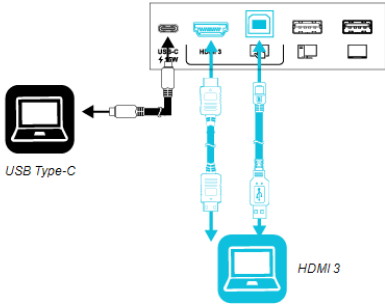

- SMART Board MX (V2) series

Side and bottom connector panels

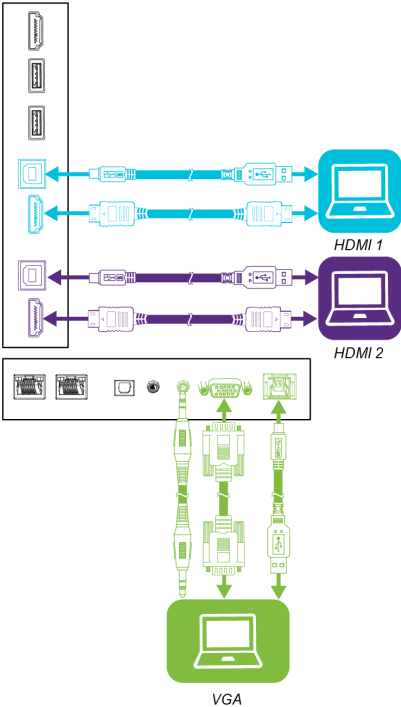

Front connector panel

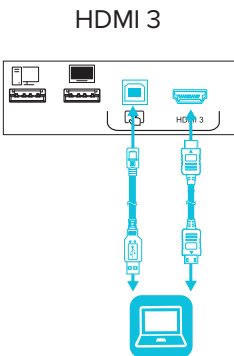

- SMART Board MX series

Side and bottom connector panels

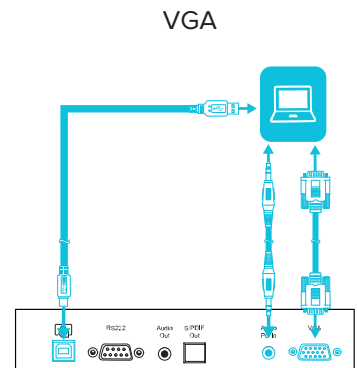
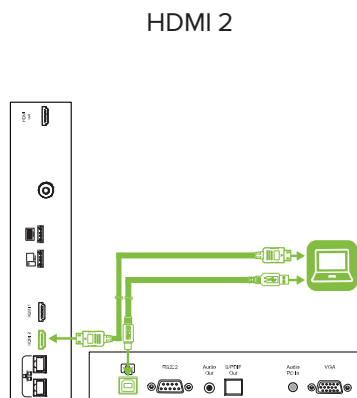
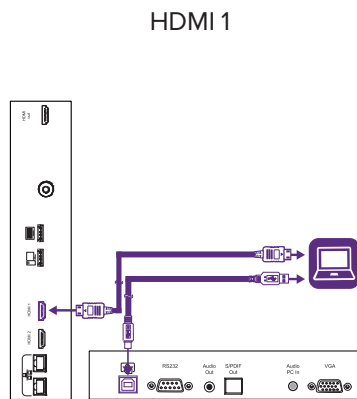

Front connector panel

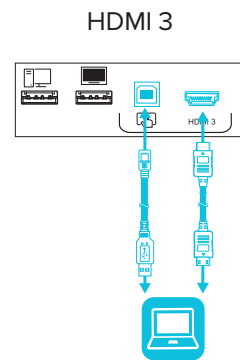





NOTES

- Install SMART software on any computers you connect to the display (see *Installing and using SMART software* on page 30).
- Your organization’s installers might have connected cables to the display and run the cables behind a wall or under the floor to a desk or table where you can place your computer.
- You can charge devices connected to the USB Type-C receptacle on the front connector panel of SMART Board MX (V2-C and V3) series interactive displays up to 15 W.
- You can charge devices connected to the USB Type-C receptacle on the side connector panel of SMART Board MX (V3) series interactive displays up to 65 W (if a module is not installed in the accessory slot) or up to 30 W (if a module is installed in the accessory slot).

Viewing a connected computer’s input

To view the input of a computer connected to a SMART Board MX (V3, V2 or V2-C) series display

1. Connect the computer to the display.
2. Do one of the following:

If iQ is enabled	If iQ is disabled
Tap Input  on the Home screen. OR Press Input  on the remote control. OR Press Input  on the front control panel.	Press the Home button  or the Input button  on the remote control.

The display shows thumbnails of the devices that are connected to the display’s inputs:

NOTE

A thumbnail with **Touch enabled**  indicates a USB cable is connected between the display and device and touch is available.

- A gray thumbnail indicates no device is connected to an input.
 - A black thumbnail indicates a device is connected to an input but is in Standby mode.
 - A thumbnail showing a preview screen indicates an active device is connected to an input.
3. Tap the computer’s thumbnail.

To view the input of a computer connected to a SMART Board MX series display

1. Connect the computer to the display.
2. Press the **Input**  on the front control panel.

The Input selection menu appears.

NOTE

Inputs with devices connected are blue, and inputs without a connection are black.

3. Tap the computer's input menu option.

Setting a connected computer's resolution and refresh rate

The following table presents the recommend resolutions and refresh rates for the display's USB-C, HDMI 1, HDMI 2, and HDMI 3 input sources:

Resolution	Input source aspect ratio	Mode	Refresh rate
3840 × 2160	16:9	UHD / 2160p	59.94 Hz / 60 Hz 50 Hz 29.97 Hz / 30 Hz 25 Hz 23.98 Hz / 24 Hz
1920 × 1080	16:9	FHD / 1080p	59.94 Hz / 60 Hz 50 Hz 29.97 Hz / 30 Hz 25 Hz 23.98 Hz / 24 Hz
1360 × 768	16:9	HD	60.015 Hz
1366 × 768	16:9	HD	60.015 Hz
1280 × 720	16:9	HD / 720p	59.94 Hz / 60 Hz 50 Hz 29.97 Hz / 30 Hz 25 Hz 23.98 Hz / 24 Hz
720 × 480	16:9	480p (DVD Player)	60 Hz

The following table presents the recommended resolutions and refresh rates for the display's VGA input source:

Resolution	Input source aspect ratio	Mode	Refresh rate
1920 × 1080	16:9	[N/A]	60.000 Hz
1600 × 1200	4:3	[N/A]	60.000 Hz
1360 × 768	16:9	[N/A]	60.015 Hz
1280 × 1024	5:4	SXGA 60	60.020 Hz
1024 × 768	4:3	XGA 60	60.004 Hz
		XGA 70	70.069 Hz
		XGA 75	75.029 Hz
800 × 600	4:3	SVGA 60	60.317 Hz
		SVGA 72	72.188 Hz
		SVGA 75	75.000 Hz
640 × 480	4:3	VGA 60	59.940 Hz

If possible, set any connected computers to these resolutions and refresh rates. See the connected computers' operating system documentation for instructions.

Connecting USB drives, peripherals, and other devices

You can use USB drives, peripherals, and other devices with a computer connected to the display using the USB receptacles on the display.

For more information, see *Connecting USB drives, peripherals, and other devices* on the next page.

Troubleshooting connected computers

For troubleshooting information for connected computers, see *Chapter 5: Troubleshooting* on page 42.

Connecting a SMART OPS PC module

If your organization has purchased a SMART OPS PC module, you or your organization's installers can install the OPS PC module in the display's accessory slot following the OPS PC module's installation instructions (smarttech.com/kb/171544). You can then view the OPS PC module's input on the display.

For more information about SMART OPS PC modules, see the *SMART OPS PC modules user guide* (smarttech.com/kb/171747).

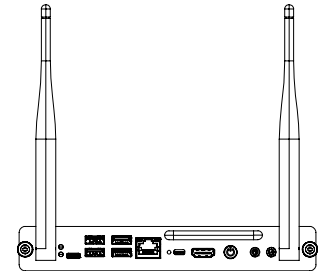

Connecting USB drives, peripherals, and other devices

The display includes the following USB Type A receptacles. You can connect USB drives, peripherals (such as keyboards), and other devices to these connectors and use the devices with the iQ experience, connected computers, and devices installed in the accessory slot (such as the SMART OPS PC module).

SMART Board MX (V3) series

SMART Board MX (V2-C) series

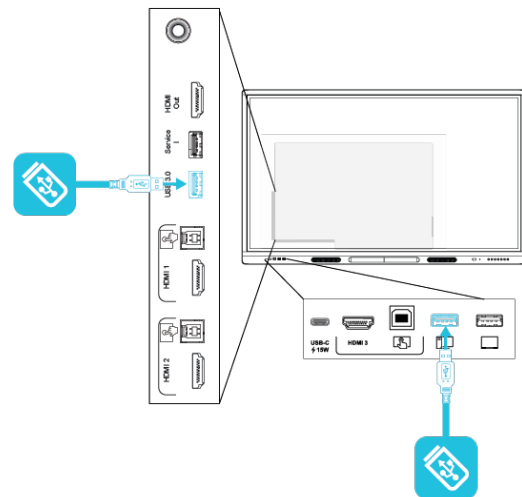
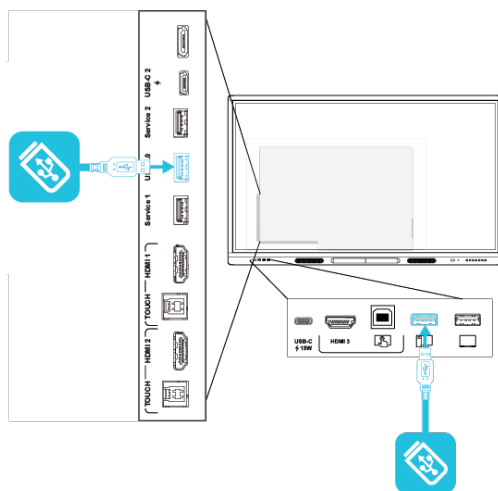

SMART Board MX (V2) series

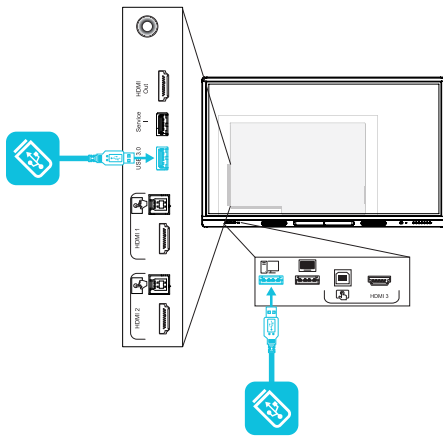

SMART Board MX series

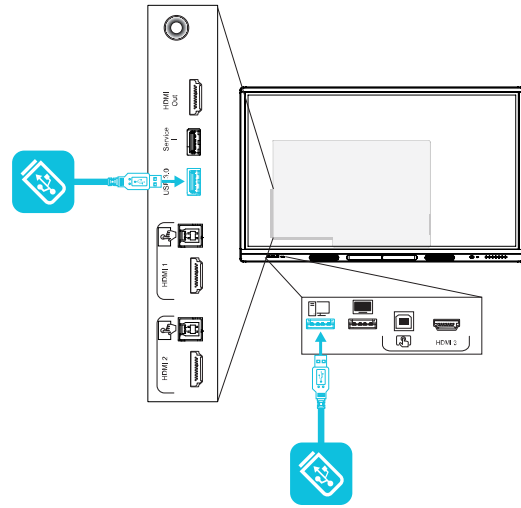

The following table shows which USB Type-A receptacles you can use with each input source and the supported USB speed:

Input source	USB 3.0 Type-A receptacle ³	USB 2.0 Type-A receptacle ⁴
iQ	✓ (SuperSpeed)	✓ (Hi-Speed)
HDMI 1	✓ (SuperSpeed)	✓ (Hi-Speed)
HDMI 2	✓ (SuperSpeed)	✓ (Hi-Speed)
HDMI 3	✓ (SuperSpeed)	✓ (Hi-Speed)
VGA	✓ (SuperSpeed)	✓ (Hi-Speed)
Accessory slot	✓ (SuperSpeed)	✓ (Hi-Speed)
OPS PC	✓ (SuperSpeed)	✓ (Hi-Speed)

³Located on the side connector panels of SMART Board MX (V2 and V2-C) series displays

⁴Located on the front connector panels of all displays and on the side connector panel of SMART Board MX series displays

Chapter 5

Troubleshooting

The display isn't turning on	42
The screen is blank or there's a problem with the image on the screen	43
There's no sound or there's a problem with the sound	45
Touch isn't working as expected	46
The pens and erasers aren't working as expected	47
iQ apps aren't working as expected	47
SMART software on connected computers isn't working as expected	48
The SMART OPS PC module isn't working as expected	48
The Intel Compute Card isn't working as expected	48
Contacting your reseller for additional support	48

This section explains how to resolve a variety of common issues with the display. If your specific symptoms aren't covered below or the solutions to the symptoms don't work, refer to the SMART knowledge base for additional troubleshooting information

community.smarttech.com/s/topic/0TO0P000000Xt5yWAC/mx-series

The display isn't turning on



Symptom	Troubleshooting steps
The power light isn't lit.	<ul style="list-style-type: none">• Make sure the power cable is securely fastened to the power outlet and the display. <hr/> <p>NOTE</p> <p>If the power cable is connected to a power bar, make sure the power bar is securely fastened to the power outlet and turned on.</p> <hr/> <ul style="list-style-type: none">• Make sure the switch beside the AC power inlet is in the ON (I) position.• Make sure the power outlet is working by testing it with a different device.• Make sure the power cable is working by testing it with a different device.
The power light is lit, but the screen is blank.	<ul style="list-style-type: none">• Press the Power button on the front of the display or on the remote control.• Restart the display.• Determine if the problem is with the video.





The screen is blank or there's a problem with the image on the screen

NOTE

If the issue occurs on the Home screen, the issue may be with the display. See *Contacting your reseller for additional support* on page 48.

If the issue doesn't occur on the Home screen, examine the connected computers or devices.

Symptom	Troubleshooting steps
The screen is blank.	<ul style="list-style-type: none">• Make sure the screen is working:<ul style="list-style-type: none">◦ On SMART Board MX (V3, V2 or V2-C) series displays, press the Home button  on the front control panel or the remote control to open the Home screen.◦ On SMART Board MX series displays, press Input  on the front control panel or the remote control, and then select OPS to switch to the iQ experience and open the Home screen.• Make sure the SMART Board MX (V3, V2 or V2-C) series display is not in Standby mode by pressing the Power button .• Make sure any connected computers are on and not in an energy saving mode.• Restart the display and any connected computers.• Replace the video cables connecting any computers to the display to determine if the issue is with the cables.
A computer is connected to the display, but only a connection message appears on the screen.	<ul style="list-style-type: none">• Make sure the computer is connected to the currently selected input.• Make sure the display supports the connected computer's refresh rate. See [XREF].• If the currently selected input is a computer, make sure the computer is not in an energy saving mode.

Symptom	Troubleshooting steps
<p>The image on the screen is distorted. OR There are lines, snow or, other visual noise on the screen. OR The image is flickering or flashing. OR The image is dim.</p>	<ul style="list-style-type: none"> On SMART Board MX (V3, V2 or V2-C) series displays, press the Home button  on the front control panel or the remote control. <p>OR</p> <p>On SMART Board MX series displays, press Input  on the front control panel or the remote control, and then select OPS.</p> <p>If the Home screen appears correctly, the issue is with the video input.</p> <ul style="list-style-type: none"> On SMART Board MX series displays, make sure the iQ appliance is securely installed in the accessory slot and its power light is on. Switch to a different input and then back to the first input. Make sure any connected computers are on and not in an energy savings mode. Restart the display and any connected computers. Set any connected computers' resolution and refresh rate to values that the display supports. See <i>Setting a connected computer's resolution and refresh rate</i> on page 38. Replace the video cables that connect any computers to the display to determine if the issue is with the cables.
<p>(For SMART Board MX (V3) and (V2-C) series displays) There is no image when using the USB Type-C receptacle with a computer</p>	<ul style="list-style-type: none"> Make sure that the computer supports Display Port Alternate Mode video via USB Type-C. Look for the Display Port logo beside the USB Type-C receptacle on the computer. If it's not there, the computer may not support Display Port Alternate Mode video via USB Type-C. Make sure the cable used with the USB Type-C receptacle supports Super Speed (5Gbps) USB. Look for the Super Speed USB logo on the cable. If the cable doesn't have the Super Speed USB logo, it may not have the internal wiring necessary to carry Display Port Alternate Mode video data.
<p>There are bright spots on the screen.</p>	<ul style="list-style-type: none"> On SMART Board MX (V3, V2 or V2-C) series displays, press the Home button  on the front control panel or the remote control. <p>OR</p> <p>On SMART Board MX series displays, press Input  on the front control panel or the remote control, and then select OPS.</p> <p>If the Home screen appears correctly, the issue is with the video input.</p> <ul style="list-style-type: none"> Take a photograph of the screen and send it to SMART support. If SMART support determines that the issue is with the screen and the display is under warranty, you may be eligible for a replacement.
<p>Colors don't appear correctly.</p>	<ul style="list-style-type: none"> Be aware that if two or more displays are mounted side-by-side, there could be minor differences in colors across the displays. This issue is not unique to SMART products. If the screen is completely lacking one color on the screen or the color problems occur on the Home screen, see <i>Contacting your reseller for additional support</i> on page 48. If you're using a VGA video input, use a different cable or connect a different source to see if the issue is with the cable or input source. Adjust the display's color settings, or reset them to the factory defaults. See [XREF].

Symptom	Troubleshooting steps
The image is cut off or shifted to the left or right.	<ul style="list-style-type: none"> Adjust any connected computers' video settings, particularly zoom, crop, and underscan. See the computer's operating system documentation. If you're using a VGA video input and any connected computers' desktops are entirely black, change them to dark gray or a different color. If any connected computers' desktops are extended across multiple screens, duplicate the desktops across the screens or set the display as the only screen.
The image doesn't fill the entire screen.	<ul style="list-style-type: none"> Adjust any connected computers' video settings, particularly overscan. See the computer's operating system documentation. Make sure the connected computer's video connector is configured to output a supported video signal. See No video display output from a laptop.
A persistent image appears on the display.	See Image persistence or burn in on LCD displays .

There's no sound or there's a problem with the sound

Symptom	Troubleshooting steps
There's no sound. OR There is sound, but the volume is low. OR The sound is distorted or muffled.	<ul style="list-style-type: none"> If you're using an external audio system, make sure it is turned on. Make sure the cables connecting the display to the computer are securely fastened. <hr/> <p>NOTES</p> <ul style="list-style-type: none"> The display's stereo 3.5 mm in connector works with the VGA input only. Connecting an audio cable to the display's stereo 3.5 mm out connector disables the internal speakers. If you're using the display's S/PDIF out connector to connect a sound bar or receiver for external speakers, see the <i>SMART Board MX (V2) and MX (V2) Pro series interactive displays installation and maintenance guide</i> (smarttech.com/kb/171555). <hr/> <ul style="list-style-type: none"> If you're using the display's stereo 3.5 mm out connector, adjust the volume on the display and the connected computer and make sure neither are muted. If you're using the display's S/PDIF out connector, adjust the volume on the external audio system and make sure the audio system isn't muted. Adjust the display's audio settings. If you're using the integrated speakers, set the volume for the computer and any running applications to 80%, and then adjust the display's volume. <p>OR</p> <p>If you're using an external audio system, set the volume for the computer, any running applications and the display to 80%, and then adjust the external audio system's volume.</p>
There is a whine or buzzing sound coming from the back of the display.	<ul style="list-style-type: none"> Be aware that these sounds are normal. All displays emit some electrical noise. Such sounds may be more noticeable with some displays than with others. However, if you hear noise from the front of the display, further investigation is required. Connect all devices to the same power outlet or power bar.

Touch isn't working as expected

Symptom	Troubleshooting steps
The display doesn't respond to touch.	<ul style="list-style-type: none">• Touch is not available right after waking up the display or turning it on. Wait a few seconds and then the display will respond to touch.• Make sure SMART Product Drivers are installed and running on connected computers. (SMART Board MX (V3) displays require SMART Product Drivers 12.18 or later, and SMART Board MX (V2-C) and (V2) displays require SMART Product Drivers 12.14 or later).• Make sure the USB cable between the display and the computer doesn't exceed the supported maximum cable length. See <i>Connecting room computers and guest laptops</i> on page 33.• Make sure any connected computers have detected the display's USB connection.• On Windows computers, open Device Manager and make sure there is no red X or yellow explanation mark (!) over the display's icon.• On Mac computers, open System Information and make sure there are no error messages in the display's row.• For Mac computers with macOS Mojave, see How to resolve issues with installing and using SMART Learning Suite software on macOS Mojave.
The display responds to touch intermittently. OR When you touch the screen, the pointer doesn't appear in the correct place.	<ul style="list-style-type: none">• Make sure jewelry or clothing doesn't touch the board when erasing the ink.• When erasing, make sure the palm or fist is flat on the screen.• Touch is not available right after waking up the display or turning it on. Wait a few seconds and then the display will respond to touch.• Restart the display.• Confirm with the installers that the computer is connected to the display with only a single cable.• Make sure SMART Product Drivers and SMART Ink are installed and running on any connected computers. Orient the display. See Orienting your SMART interactive product using SMART Product Drivers 12.• Remove infrared sources, such as incandescent or arc lights, desk lamps, and infrared audio devices, or move the display to another location in the room.• Remove any USB extenders to help isolate the USB cable.• Update the firmware.

The pens and erasers aren't working as expected

Symptom	Troubleshooting steps
The display doesn't respond to touch or writing with a pen.	<ul style="list-style-type: none">• Make sure SMART Product Drivers are installed and running on connected computers. (SMART Board MX (V3) displays require SMART Product Drivers 12.18 or later, and SMART Board MX (V2-C) and (V2) displays require SMART Product Drivers 12.14 or later).• Touch is not available right after waking up the display or turning it on. Wait a few seconds and then the display will respond to touch.• Make sure any connected computers have detected the display's USB connection.• On Windows computers, open Device Manager and make sure there is no red X or yellow explanation mark (!) over the display's icon.• On Mac computers, open System Information and make sure there are no error messages in the display's row.• Reinstall or update SMART Product Drivers and SMART Ink on any connected computers.
The display responds to touch but not to writing with a pen.	<ul style="list-style-type: none">• Reinstall or update SMART Product Drivers and SMART Ink on any connected computers.
When you write on the screen, the ink appears in the wrong place. OR Writing is intermittent. OR Ink disappears as you write.	<ul style="list-style-type: none">• Make sure you are using a SMART Board MX or MX Pro series interactive display pen.• Restart the display.• Confirm with the installers that the computer is connected to the display with only a single cable.• Make sure SMART Product Drivers and SMART Ink are installed and running on any connected computers.• Make sure the pen nib is not worn. Replacement pens are available from the Store for SMART Parts (see smarttech.com/Support/PartsStore).• Make sure SMART Product Drivers and SMART Ink are installed and running on any connected computers. Orient the display. See Orienting your SMART interactive product using SMART Product Drivers 12.• Remove infrared sources, such as incandescent or arc lights, desk lamps, and infrared audio devices, or move the display to another location in the room.• Update the firmware.
You can't write or draw in Microsoft® Office.	<ul style="list-style-type: none">• Make sure Microsoft Office 2013 or later is installed.• Reinstall or update SMART Product Drivers and SMART Ink.

iQ apps aren't working as expected

Symptom	Troubleshooting steps
iQ apps aren't working as expected.	See Troubleshooting the iQ experience .

SMART software on connected computers isn't working as expected

Symptom	Troubleshooting steps
SMART Notebook software isn't working as expected.	See Troubleshooting SMART Notebook .
Lumio by SMART isn't working as expected.	See Troubleshooting common issues in Lumio by SMART .
SMART Ink isn't working as expected.	See Troubleshooting SMART Ink .
SMART Product Drivers isn't working as expected.	See Troubleshooting SMART Product Drivers .

The SMART OPS PC module isn't working as expected

Symptom	Troubleshooting steps
The SMART OPS PC module isn't working as expected.	See the <i>SMART OPS PC modules user guide</i> (smarttech.com/kb/171747).

The Intel Compute Card isn't working as expected

Symptom	Troubleshooting steps
The Intel Compute Card isn't working as expected.	See Troubleshooting the iQ appliance (AM50) and Intel Compute Card .

Contacting your reseller for additional support

If an issue you're experiencing with the display persists or isn't covered in this chapter or the knowledge base, contact your authorized SMART reseller (smarttech.com/where) for support.

Your reseller might ask you for the display's serial number.

For SMART Board MX (V3, V2 and V2-C) series displays, the serial number is on a label located on the left side of the display (pictured).

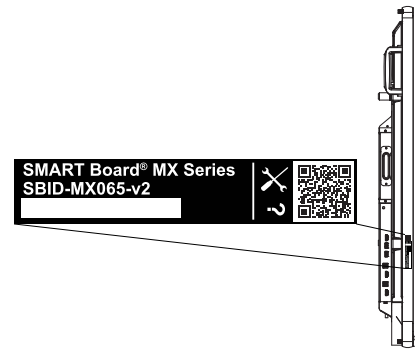

TIP

Scan the QR code on the label to view the SMART Board MX or MX Pro series interactive display support pages on the SMART website.

For SMART Board MX series displays, the serial number is on labels located on the bottom frame and the back of the display.

NOTE

To find the serial number for the iQ appliance and Intel Compute Card, see [Getting support and finding serial numbers for your iQ appliance and Intel Compute Card](#).

You can also find the serial number in the settings. Refer to the *SMART Board MX and MX Pro series interactive displays installation and maintenance guide* (smarttech.com/kb/171555) for more information.

SMART TECHNOLOGIES

smarttech.com/support

smarttech.com/contactsupport

smarttech.com/kb/171554