



# NUC 15 Pro

NUC15CRS

NUC15CRS-B

User Guide

Regulatory Model: NUC15CRS

## **Important information**

### **Copyright Information**

No part of this manual, including the products and software described in it, may be reproduced, transmitted, transcribed, stored in a retrieval system, or translated into any language in any form or by any means, except documentation kept by the purchaser for backup purposes, without the express written permission of ASUSTeK COMPUTER INC. ("ASUS").

ASUS provides this manual "as is" without warranty of any kind, either express or implied, including but not limited to the implied warranties or conditions of merchantability or fitness for a particular purpose. In no event shall ASUS, its directors, officers, employees or agents be liable for any indirect, special, incidental, or consequential damages (including damages for loss of profits, loss of business, loss of use or data, interruption of business and the like), even if ASUS has been advised of the possibility of such damages arising from any defect or error in this manual or product.

Products and corporate names appearing in this manual may or may not be registered trademarks or copyrights of their respective companies, and are used only for identification or explanation and to the owners' benefit, without intent to infringe.

Specifications and information contained in this manual are furnished for informational use only, and are subject to change at any time without notice, and should not be construed as a commitment by ASUS. ASUS assumes no responsibility or liability for any errors or inaccuracies that may appear in this manual, including the products and software described in it.

Copyright © 2025 ASUSTeK COMPUTER INC. All Rights Reserved.

### **Limitation of Liability**

Circumstances may arise where because of a default on ASUS' part or other liability, you are entitled to recover damages from ASUS. In each such instance, regardless of the basis on which you are entitled to claim damages from ASUS, ASUS is liable for no more than damages for bodily injury (including death) and damage to real property and tangible personal property; or any other actual and direct damages resulted from omission or failure of performing legal duties under this warranty statement, up to the listed contract price of each product.

ASUS will only be responsible for or indemnify you for loss, damages or claims based in contract, tort or infringement under this warranty statement.

This limit also applies to ASUS' suppliers and its reseller. It is the maximum for which ASUS, its suppliers, and your reseller are collectively responsible.

Under no circumstances is ASUS liable for any of the following: (1) third-party claims against you for damages; (2) loss of, or damage to, your records or data; or (3) special, incidental, or indirect damages or for any economic consequential damages (including lost profits or savings), even if ASUS, its suppliers or your reseller is informed of their possibility.

### **Accessibility Statement**

ASUS is committed to making our documentation accessible, in accordance with Directive (EU) 2019/882 of the European Parliament and of the Council. This document is designed to meet requirements for WCAG 2.1 (level AA)/EN 301 549 and be accessible to screen readers such as NVDA Screen Reader or Microsoft Narrator.

### **Service and Support**

Visit our multi-language website at <https://www.asus.com/support/>.

# Table of Contents

|   |    |
|---|----|
| Important information .....             | 2  |
| Table of Contents.....                  | 3  |
| Safety and caution information.....     | 6  |
| Package contents .....                  | 7  |
| Front view .....                        | 8  |
| Rear view .....                         | 8  |
| NUC Mini PC setup guide .....           | 9  |
| Connecting the display .....            | 9  |
| Connecting the keyboard and mouse ..... | 12 |
| Connecting the LAN cable.....           | 13 |
| Connecting the power adapter.....       | 14 |
| Powering on the system .....            | 17 |
| Managing power modes.....               | 18 |
| Enabling fast startup .....             | 20 |
| NUC component integration guide .....   | 21 |
| Safety precautions .....                | 21 |
| Care during use .....                   | 22 |
| Before you begin .....                  | 23 |
| Opening system .....                    | 24 |
| DDR5 SODIMM/CSODIMM installation.....   | 25 |
| M.2 installation.....                   | 26 |
| Closing system.....                     | 28 |
| VESA mount installation.....            | 29 |

## About this guide

This user guide includes information on the following NUC SKUs:

- **NUC Mini PC**  
**(Memory and M.2 solid state drive(s) already included in the NUC system; Windows 11 64-bit Operating System included):**  
Specifications and steps to set up your NUC Mini PC.
- **NUC Kit (barebones)**  
**(Memory and M.2 solid state drive not included; Operating system not included):**  
Specifications and steps to set up your NUC Kit.

---

**NOTE:** Memory, M.2 solid state drive, and operating system are purchased separately for this SKU.

---

## Audience

This user guide is intended to provide basic setup information about the NUC Mini PC, NUC Kit and components to vendors, system integrators, and other engineers and technicians who need this level of information.

## Conventions used in this guide

To highlight key information in this manual, some text are presented as follows:

---

**IMPORTANT!** This message contains vital information that must be followed to complete a task.

---

---

**NOTE:** This message contains additional information and tips that can help complete tasks.

---

---

**WARNING!** This message contains important information that must be followed to keep you safe while performing certain tasks and prevent damage to your NUC system's data and components.

---

## Other Common Notation

| Abbrev. | Description   |
|---------|---|
| #       | Used after a signal name to identify an active-low signal (such as USBP0#)        |
| GB      | Gigabyte (1,073,741,824 bytes)  |
| GB/s    | Gigabytes per second  |
| Gb/s    | Gigabits per second   |
| KB      | Kilobyte (1024 bytes)   |
| Kb      | Kilobit (1024 bits)   |
| kb/s    | 1000 bits per second  |
| MB      | Megabyte (1,048,576 bytes)  |
| MB/s    | Megabytes per second  |
| Mb      | Megabit (1,048,576 bits)  |
| Mb/s    | Megabits per second   |
| TDP     | Thermal Design Power  |
| xxh     | An address or data value ending with a lowercase h indicates a hexadecimal value. |
| x.x V   | Volts. Voltages are DC unless otherwise specified.                                |
| x.x A   | Amperes.  |

## Production identification information

ASUSTeK NUC Product NUC 15 Pro+ Identification Information

| Product Name | NUC 15 Pro |
|--------------|------------|
| NUC15CRS-B   | Kit        |
| NUC15CRS     | Mini PC    |

## Where to find more information

Refer to the following sources for additional information and for product and software updates.

### ASUS website

The ASUS website ([www.asus.com](http://www.asus.com)) provides updated information on ASUS hardware and software products.

## Safety and caution information

- Accessories that came with this product have been designed and verified for the use in connection with this product. Never use accessories from other products to prevent the risk of electric shock or fire.
- This device may interfere with the operation of some pacemakers, hearing aids or other medical devices. To reduce the risk, maintain a separation distance of 20cm (8 inches) between the device and the medical device. Refer to the medical device for additional information.
- Modification of the wireless solution, thermal solution, device components or enclosure shall violate regulatory compliance requirements and may induce safety hazards.



Risk of explosion if the battery is replaced with an incorrect type. Batteries should be recycled where possible. Disposal of used batteries must be in accordance with local environmental regulations.

# Package contents

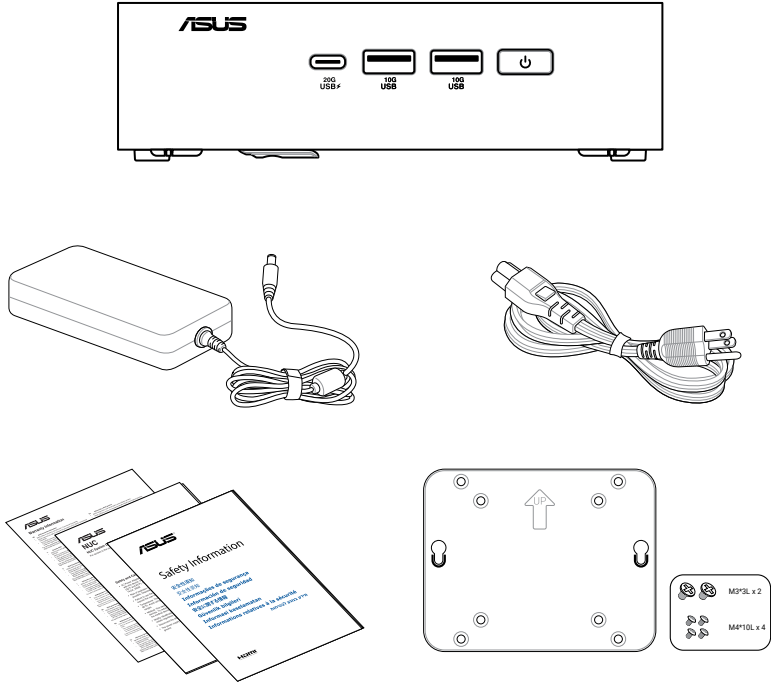

---

## NOTE:

- The most up-to-date and accurate product specifications are available on [www.asus.com](http://www.asus.com) for download.
  - Product and accessory images are for illustrative purposes only. The actual appearance and specifications may vary depending on the model.
  - The bundled power adapter may vary depending on the model and the country (or region) of sale.
  - The availability of the power cord may vary depending on the country (or region) of sale.
  - Some bundled accessories may vary depending on the model. For details on these accessories, refer to their respective user manuals.
  - If the device or its components fail or malfunction during normal and proper use within the warranty period, bring the warranty card to the ASUS Service Center for replacement of the defective components.
-

## Front view

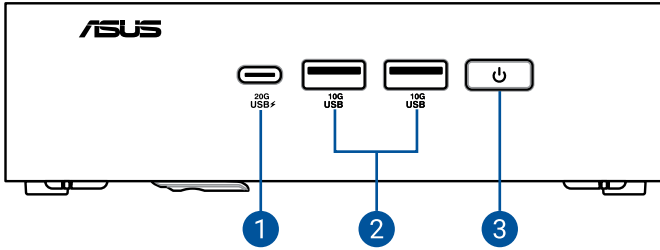

## Rear view

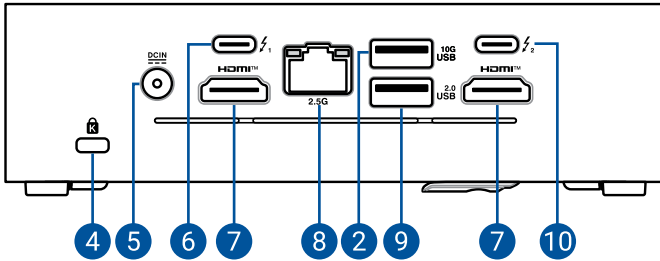

1. USB 20Gbps Type-C® port
2. USB 10Gbps port
3. Power button
4. Kensington lock
5. Power input
6. Thunderbolt™ 4 Type-C® port 1 with DisplayPort 2.1
7. HDMI™ port
8. LAN Port
9. USB 2.0 port
10. Thunderbolt™ 4 Type-C® port 2 with DisplayPort 2.1

**NOTE:** Type-C® port power profiles:

- 5V @ 3A (primary)
- 5V @ 1.5A (secondary)

# NUC Mini PC setup guide

## Connecting the display

### HDMI™ port

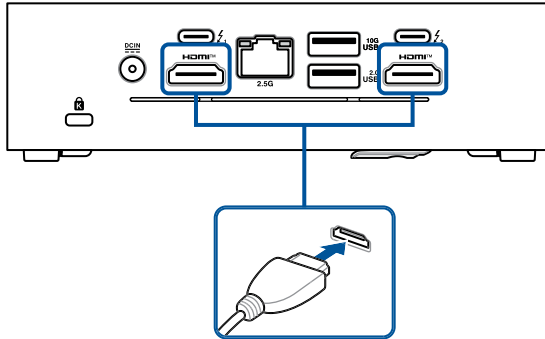

### Type-C® DisplayPort

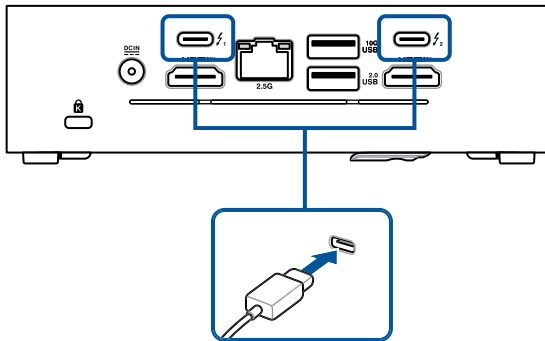

## Display resolution table:

### Single Display

| Port Combination          | Resolution/Refresh for Individual Port(s) |                        |                        |                        |
|---------------------------|---|------------------------|------------------------|------------------------|
|                           | HDMI 1                                    | Type-C® TBT/<br>DP 1   | Type-C® TBT/<br>DP 2   | HDMI 2                 |
| HDMI 1 (2.1 TMDS)         | 4K (3840 x 2160 @60Hz)                    | -                      | -                      | -                      |
| Type-C® TBT/DP 1          | -   | 5K (5120 x 3200 @60Hz) | -                      | -                      |
| Type-C® TBT/DP 2          | -   | -                      | 5K (5120 x 3200 @60Hz) | -                      |
| HDMI 2(2.1 TMDS)          | -   | -                      | -                      | 4K (3840 x 2160 @60Hz) |
| Both Type-C® TBT/DP 1 & 2 | -   | 8K (7680 x 4320 @60Hz) |                        |                        |

### Dual Displays

| Port Combination                     | Resolution/Refresh for Individual Port(s) |                        |                        |                        |
|--------------------------------------|---|------------------------|------------------------|------------------------|
|                                      | HDMI 1                                    | Type-C® TBT/<br>DP 1   | Type-C® TBT/<br>DP 2   | HDMI 2                 |
| HDMI 1 (2.1 TMDS) + Type-C® TBT/DP 1 | 4K (3840 x 2160 @60Hz)                    | 5K (5120 x 3200 @60Hz) | -                      | -                      |
| HDMI 1 (2.1 TMDS) + Type-C® TBT/DP 2 | 4K (3840 x 2160 @60Hz)                    | -                      | 5K (5120 x 3200 @60Hz) | -                      |
| HDMI 1 (2.1 TMDS) + HDMI 2(2.1 TMDS) | 4K (3840 x 2160 @60Hz)                    | -                      | -                      | 4K (3840 x 2160 @60Hz) |
| Type-C® TBT/DP 1 + Type-C® TBT/DP 2  | -   | 5K (5120 x 3200 @60Hz) | 5K (5120 x 3200 @60Hz) | -                      |
| Type-C® TBT/DP 1 + HDMI 2 (2.1 TMDS) | -   | 5K (5120 x 3200 @60Hz) | -                      | 4K (3840 x 2160 @60Hz) |
| Type-C® TBT/DP 2 + HDMI 2 (2.1 TMDS) | -   | 5K (5120 x 3200 @60Hz) | -                      | 4K (3840 x 2160 @60Hz) |

## Triple Displays

| Port Combination   | Resolution/Refresh for Individual Port(s) |                           |                           |                           |
|--|---|---------------------------|---------------------------|---------------------------|
|  | HDMI 1                                    | Type-C® TBT/<br>DP 1      | Type-C® TBT/<br>DP 2      | HDMI 2                    |
| HDMI 1 (2.1 TMDS) +<br>Type-C® TBT/DP 1 +<br>Type-C® TBT/DP 2  | 4K (3840 x 2160<br>@60Hz)                 | 4K (3840 x 2160<br>@60Hz) | 4K (3840 x 2160<br>@60Hz) | -                         |
| HDMI 2 (2.1 TMDS) +<br>Type-C® TBT/DP 1 +<br>Type-C® TBT/DP 2  | -   | 4K (3840 x 2160<br>@60Hz) | 4K (3840 x 2160<br>@60Hz) | 4K (3840 x 2160<br>@60Hz) |
| HDMI 1 (2.1 TMDS) +<br>Type-C® TBT/DP 1 +<br>HDMI 2 (2.1 TMDS) | 4K (3840 x 2160<br>@60Hz)                 | 5K (5120 x 3200<br>@60Hz) | -                         | 4K (3840 x 2160<br>@60Hz) |
| HDMI 1 (2.1 TMDS) +<br>Type-C® TBT/DP 2 +<br>HDMI 2 (2.1 TMDS) | 4K (3840 x 2160<br>@60Hz)                 | -                         | 5K (5120 x 3200<br>@60Hz) | 4K (3840 x 2160<br>@60Hz) |

## Quad Displays

| Port Combination   | Resolution/Refresh for Individual Port(s) |                           |                           |                           |
|--|---|---------------------------|---------------------------|---------------------------|
|  | HDMI 1                                    | Type-C® TBT/<br>DP 1      | Type-C® TBT/<br>DP 2      | HDMI 2                    |
| HDMI 1 (2.1 TMDS) +<br>Type-C® TBT/DP 1 +<br>Type-C® TBT/DP 2 +<br>HDMI 2 (2.1 TMDS) | 4K (3840 x 2160<br>@60Hz)                 | 4K (3840 x 2160<br>@60Hz) | 4K (3840 x 2160<br>@60Hz) | 4K (3840 x 2160<br>@60Hz) |

## Daisy Chain Quad Displays

| Port Combination  | Resolution/Refresh for Individual Port(s) |   |  |                           |
|---|---|---|--|---------------------------|
|   | HDMI 1                                    | Type-C® TBT/<br>DP 1                                    | Type-C® TBT/<br>DP 2                                   | HDMI 2                    |
| HDMI 1 (2.1 TMDS) +<br>Type-C® TBT/DP 1 (daisy<br>chain) +<br>HDMI 2 (2.1 TMDS) | 4K (3840 x 2160<br>@60Hz)                 | 4K (3840 x 2160<br>@60Hz)<br>4K (3840 x 2160<br>@60Hz)  | -  | 4K (3840 x 2160<br>@60Hz) |
| HDMI 1 (2.1 TMDS) +<br>Type-C® TBT/DP 2 (daisy<br>chain) +<br>HDMI 2 (2.1 TMDS) | 4K (3840 x 2160<br>@60Hz)                 | -   | 4K (3840 x 2160<br>@60Hz)<br>4K (3840 x 2160<br>@60Hz) | 4K (3840 x 2160<br>@60Hz) |
| Type-C® TBT/DP 1 (daisy<br>chain) +<br>Type-C® TBT/DP 1(daisy<br>chain)         | -   | -4K (3840 x 2160<br>@60Hz)<br>4K (3840 x 2160<br>@60Hz) | 4K (3840 x 2160<br>@60Hz)<br>4K (3840 x 2160<br>@60Hz) | -                         |

# Connecting the keyboard and mouse

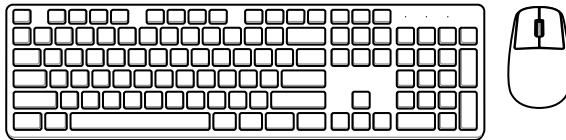
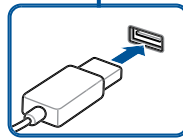
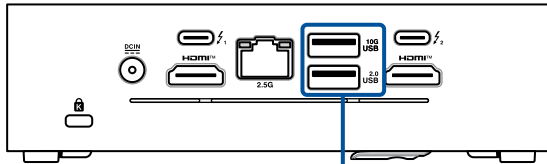
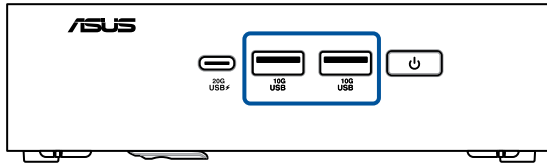

## Connecting the LAN cable

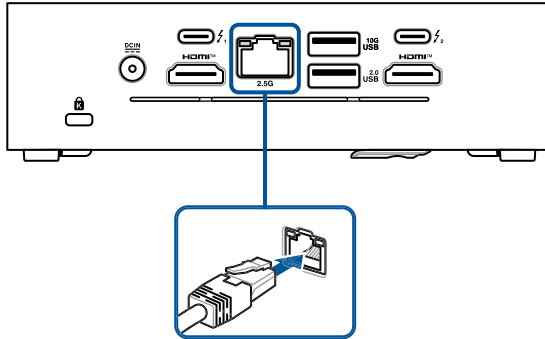

## LAN port LED indications:



| Link LED |               |
|----------|---------------|
| Status   | Description   |
| OFF      | No link       |
| GREEN    | Linked        |
| BLINKING | Data activity |

| Speed LED |                               |
|-----------|-------------------------------|
| Status    | Description                   |
| OFF       | 100 Mbps / 10 Mbps connection |
| YELLOW    | 1 Gbps connection             |
| GREEN     | 2.5 Gbps connection           |

## Connecting the power adapter

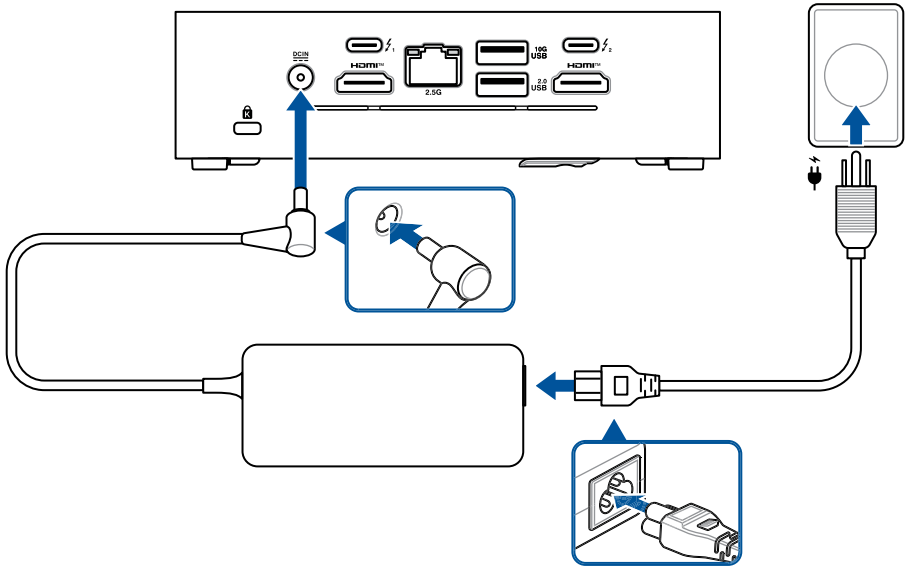

---

**NOTE:** Please refer to the following for more information on the adapter and the system:

120W Power adapter

- Input voltage: 100-240 Vac
- Input frequency: 50-60 Hz
- Output current: 6.32A (120.0 W)
- Output voltage: 19 Vdc
- Rated for use between 0°C and 40°C (32°F and 104°F)

150W Power adapter

- Input voltage: 100-240 Vac
- Input frequency: 50-60 Hz
- Output current: 7.7A (150.0 W)
- Output voltage: 19.5 Vdc
- Rated for use between 0°C and 40°C (32°F and 104°F)

System (Core Ultra 5, Core Ultra 7)

- Rated input current: 6.32A (120.0 W)
- Rated input voltage: 19 Vdc
- Operating temperature: 0°C to 40°C (32°F and 104°F)

System (Core Ultra 9)

- Rated input current: 7.7A (150.0 W)
  - Rated input voltage: 19.5 Vdc
  - Operating temperature: 0°C to 40°C (32°F and 104°F)
-

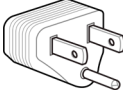
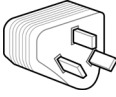
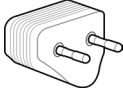
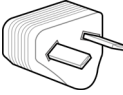
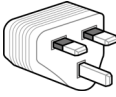
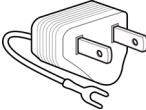
| <b>Plug</b>   | <b>Code</b> | <b>Country</b> |
|---|-------------|----------------|
|  | US          | United States  |
|  | CN          | China          |
|  | EU          | European Union |
|  | AU          | Australia      |
|  | UK          | United Kingdom |
|  | JP          | Japan (Type-A) |

## Powering on the system

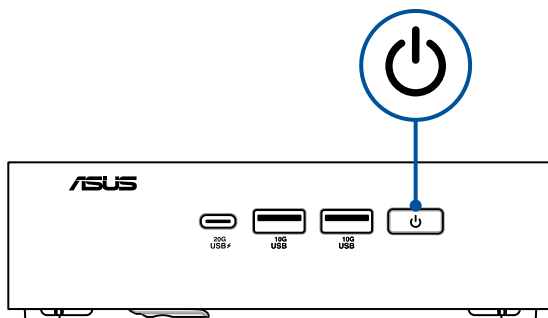

---

**NOTE:** To view the current power management settings in Windows® 11, click the **Start Button**. Type Power Management, then press <Enter>.

---

Default settings on a new system, as received, has the recommended settings (below) applied.

---

**NOTE:** This section only applies to the NUC Mini PC, and is not applicable to the NUC Kit or NUC Board.

---

## BIOS settings

---

**NOTE:** Enter BIOS Setup by pressing **F2** during startup. If you're using this system at home, it is unlikely you will need to alter these settings.

---

- Fan mode - Set to Standard.
- After Power Failure - System stays off; press the power button to restart.
- Modern standby indicator - Power light on the front of the system will blink on and off. (This is sleep mode)
- Wake-on-LAN S5 - System will power up to a normal boot. (This is for IT departments)

## Operating System Settings (Windows® 11)

- Turn Off the Display - 5 Minutes. (Your monitor will go blank)
- Put the Computer to Sleep - Within 5 minutes of user inactivity.

### To Wake Your Computer

- To wake your system up from display sleep or HDD power off
- Put the Computer to Sleep - Within 5 minutes of user inactivity.

## Managing power modes

### Putting your NUC system to the Off mode with fast startup enabled

You can put your NUC system to the Off mode with fast startup enabled:

Enter **Control Panel** in the search bar and open it (**View by: Category**), select **Hardware and Sound > Power Options > Choose what the power button does**, click **Change settings that are currently unavailable**, select **Turn on fast startup (recommended)** and click **Save changes**.

- Launch the Start menu, select the power icon then select **Shut down** to do a normal shutdown.  
From the log-in screen, select the power icon then select **Shut down**.
- Press <alt> + <F4> to launch Shut Down Windows. Select **Shut down** from the drop-down list then select **OK**.

If your NUC system is unresponsive, press and hold the power button for at least four (4) seconds until your NUC system turns off.

### Putting your NUC system to sleep

You can put your NUC system to Sleep mode in two ways:

- Launch the Start menu, select the power icon then select **Sleep** to put your NUC system to sleep.  
From the log-in screen, select the power icon then select **Sleep**.
- Press <alt> + <F4> to launch Shut Down Windows. Select **Sleep** from the drop-down list then select **OK**.

---

**NOTE:** You can also put your NUC system to Sleep mode by pressing the power button once.

---

## Putting your NUC system to the lowest power mode

You can put your NUC system to the lowest power mode by following the steps below:

- Enter BIOS setup by pressing <F2> or <Del> during the boot process.
- Go to **Power > Secondary Power Settings > ErP Ready**, and select **Enabled**.

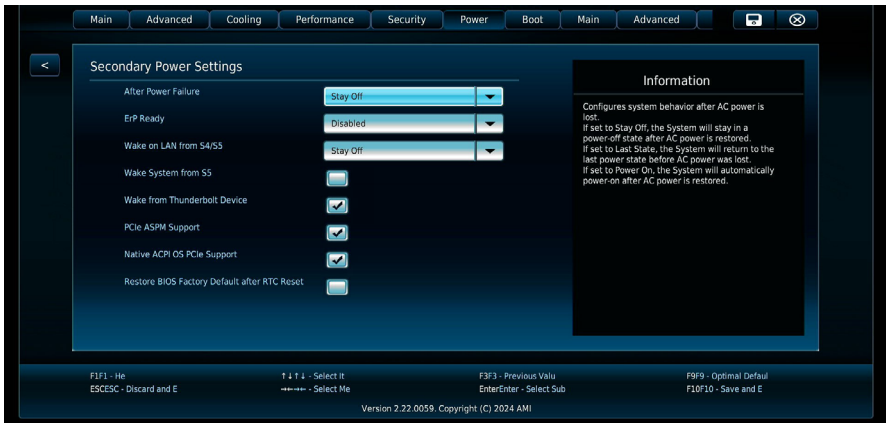

- Enter **Control Panel** in the search bar and open it (**View by: Category**), select **Hardware and Sound > Power Options > Choose what the power button does**, click **Change settings that are currently unavailable**, clear **Turn on fast startup (recommended)** and click **Save changes**.
- Launch the Start menu, select the power icon then select **Shut down** to do a normal shutdown.  
From the log-in screen, select the power icon then select **Shut down**.
- Press <alt> + <F4> to launch Shut Down Windows. Select **Shut down** from the drop-down list then select **OK**.  
If your NUC system is unresponsive, press and hold the power button for at least four (4) seconds until your NUC system turns off.

## Enabling fast startup

You can shut down the your NUC system with fast startup enabled.

To enable fast startup in Shutdown settings:

Enter **Control Panel** in the search bar and open it (**View by: Category**), select **Hardware and Sound > Power Options > Choose what the power button does**, click **Change settings that are currently unavailable**, select **Turn on fast startup (recommended)** and click **Save changes**.

---

**NOTE:** If fast startup is disabled, when you shut down the your NUC system, it shuts down to the S5 power state.

---

# NUC component integration guide

---

**IMPORTANT!** ASUS is not responsible for direct, indirect, intentional or unintentional damages resulting from improper installation and operation.

---

**NOTE:** The illustrations in this section are for reference only. The chassis may vary between models, but the installation/removal steps remain the same.

---

## Safety precautions

- This device is intended for use in ambient temperatures between 0°C and 40°C (32°F and 104°F). Avoid using or storing next to heat sources, in direct sunlight, or outside the intended temperature ranges.
- Do not use this product near water or a heated source.
- Openings on the chassis are for ventilation. Do not block or cover these openings. Make sure you leave plenty of space around the system for ventilation. Never insert objects of any kind into the ventilation openings.
- Use this product in environments with ambient temperatures between 0°C and 40°C.
- Failure to use the included power adapter shall violate regulatory compliance requirements and may expose the user to safety hazards.
- Risk of electric shock, fire, or burn if using an AC adapter other than the one provided with this device. Indoor use only and in dry locations. The adapter is rated for use between 0°C and 40°C (32°F and 104°F).
- If you use an extension cord, make sure that the total ampere rating of the devices plugged into the extension cord does not exceed its ampere rating.
- The power supply cord must be plugged into a socket or outlet that is provided with a suitable earth ground.
- This equipment should be installed and operated with a minimum distance of 20cm between the radiator and your body.
- Do not install this equipment at a height exceeding 2 meters

## Care during use

- Do not walk on the power cord or allow anything to rest on it.
- Do not spill water or any other liquids on your system.
- When the system is turned off, a small amount of electrical current still flows. Always unplug the power cord from the power outlets before cleaning the system.
- If you encounter the following technical problems with the product, unplug the power cord and contact a qualified service technician or your retailer.
  - The power cord or plug is damaged.
  - Liquid has spilled into the system.
  - The system does not function properly even if you follow the operating instructions.
  - The system was dropped, or the cabinet is damaged.
  - The system performance changes.
- Avoid contact with hot components inside the Mini PC. During operation, some components become hot enough to burn the skin. Before you open the computer cover, turn off the computer, disconnect the power, and wait approximately 30 minutes for the components to cool.
- Disposal of a battery into fire or a hot oven, or mechanically crushing or cutting of a battery, that can result in an explosion.
- Leaving a battery in an extremely high temperature surrounding environment that can result in an explosion or the leakage of flammable liquid or gas.
- A battery subjected to extremely low air pressure that may result in an explosion or the leakage of flammable liquid or gas.

## Before you begin

1. Read the entire manual before starting any service procedures and follow all instructions.
  2. Back up your NUC system.
  3. Turn off your NUC system.
  4. Place your NUC system on a stable surface.
  5. Disconnect all connected peripherals and cables.
- 

### **IMPORTANT!**

- Purchase replacement components from an authorized retailer of this NUC system to ensure maximum compatibility and reliability.
  - Refer to <https://www.asus.com> for a list of compatible components.
- 

### **NOTE:**

- The illustrations are for reference only.
  - Product and component images are for illustrative purposes only. The actual appearance and specifications may vary depending on the model.
  - Keep all adhesive tape, insulating materials, screws, and other removable items in a safe place until the service procedure is completed, as they may be needed during installation.
-

## Opening system

1. Completely loosen the latch lock screw.

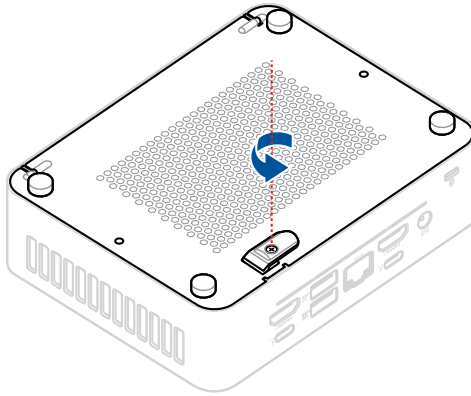

2. Lift the latch lock to unlock the bottom cover.
3. Lift and flip open the bottom cover.

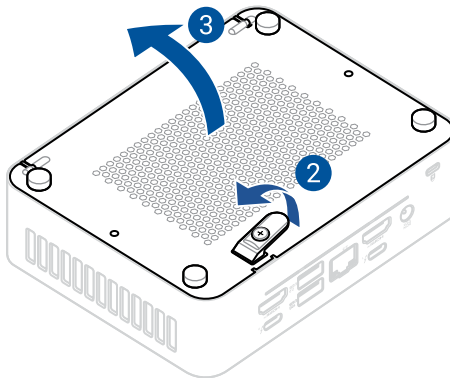

## DDR5 SODIMM/CSODIMM installation

To install memory, be sure to select memory modules that meet these requirements:

- 1.1V low voltage memory
- DDR5 5200/5600 MHz SODIMMs
- DDR5 6400 MHz CSODIMMs
- Non-ECC
- Up to 96 GB of system memory with two SODIMMs or two CSODIMMs using 48 GB memory modules

Find compatible and validated memory modules in the ASUS Qualified Vendor List at [www.asus.com/support](http://www.asus.com/support).

---

**NOTE:** 2 Gb, 4 Gb, and 8 Gb memory technology (SDRAM Density) is not supported.

---

1. Align the small space at the bottom edge of the DDR5 SODIMM/CSODIMM with the key on the SODIMM slot, then insert the DDR5 SODIMM/CSODIMM into the SODIMM slot.
2. Push the DDR5 SODIMM/CSODIMM down until the retaining clips clicks into place.

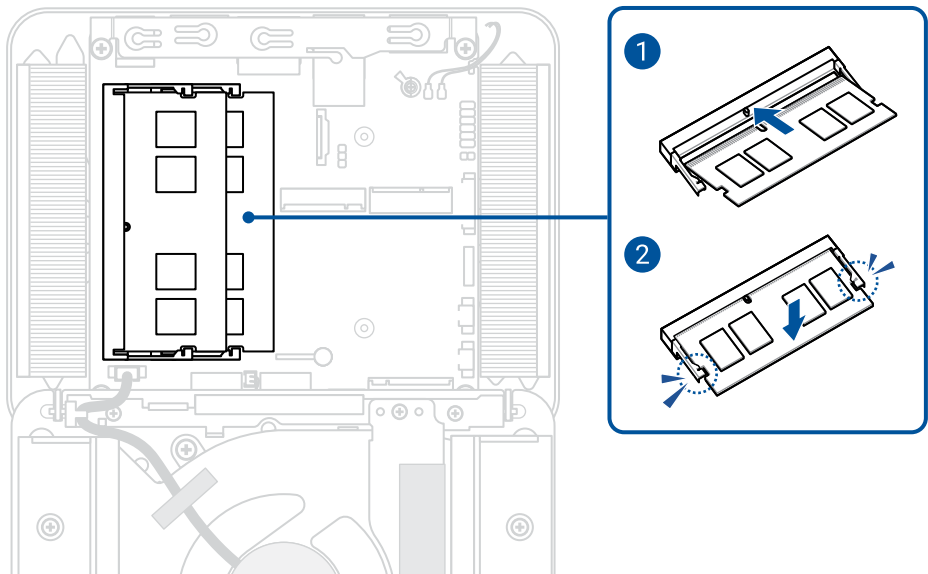

## M.2 installation

This system supports the following:

- One M.2 PCIe Gen5x4 connector supporting M.2 22x80 (key type M) for NVMe SSD.
- One M.2 PCIe Gen4x4 connector supporting M.2 22x42 (key type M) for NVMe SSD.

Find compatible and validated M.2 modules in the ASUS Qualified Vendor List at [www.asus.com/support](http://www.asus.com/support).

### 2280 M.2

1. Insert the M.2 module into the M.2 slot on the system board.
2. Rotate the Q-Latch counterclockwise to secure the M.2 module in place.

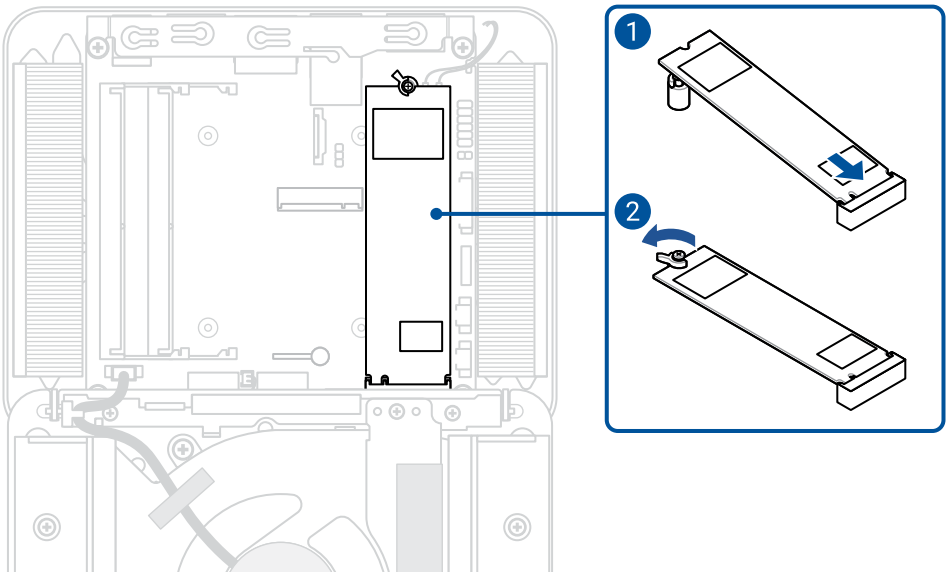

## 2242 M.2

1. Pull the pin of the M.2 anchor upwards so that the pin is completely pulled out.
2. Align and insert the M.2 module.
3. Gently push the M.2 module down on top of the M.2 anchor, and secure it by pushing the pin of the M.2 anchor into the hole.

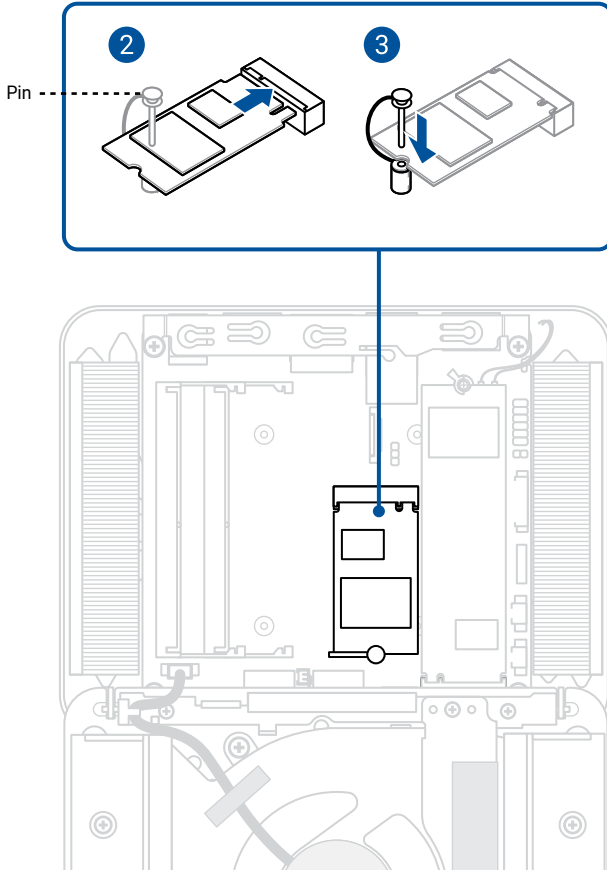

## Closing system

1. Close the bottom cover.

---

**NOTE:** Ensure the bottom cover is closed properly. A loud click should be heard when the bottom cover is properly closed.

---

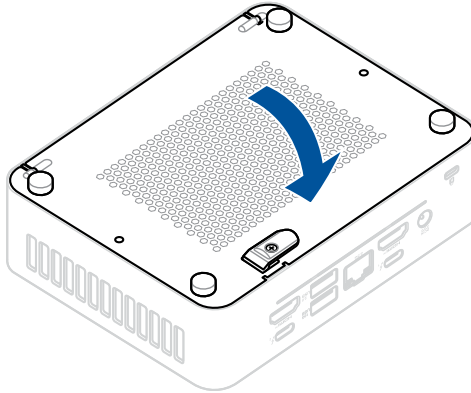

2. Secure the bottom cover by tightening the latch lock screw.

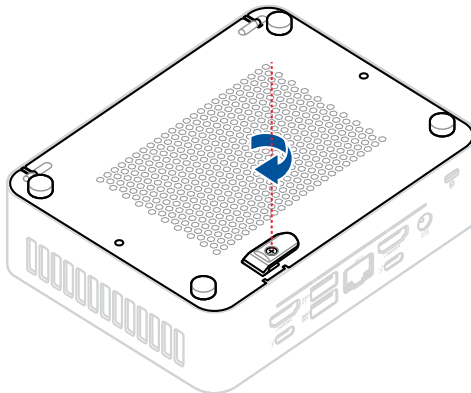

## VESA mount installation

1. Attach the VESA bracket to the back of the monitor or TV using the four (4) bundled screws with the THIS WAY UP arrow indicator pointing upwards.

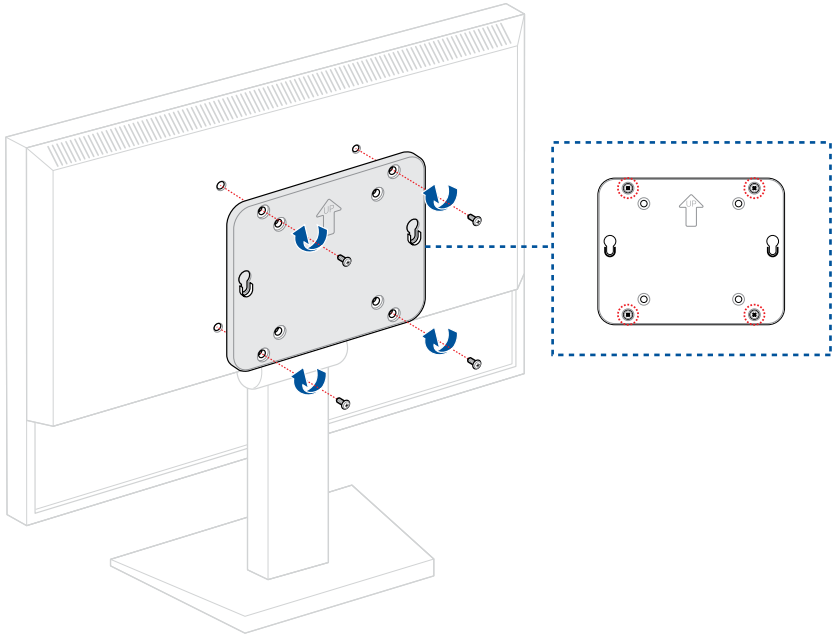

2. Attach the two (2) bundled slightly larger black screws to the bottom chassis cover of the NUC system.

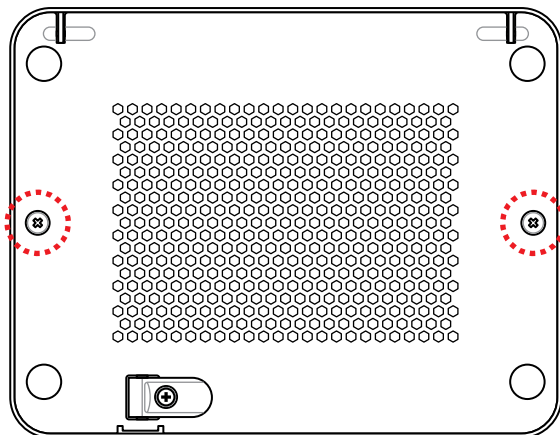

3. Align the screws on the NUC system to the notches on the VESA mount.

---

**NOTE:** Your NUC system will be tilted slightly when properly aligned.

---

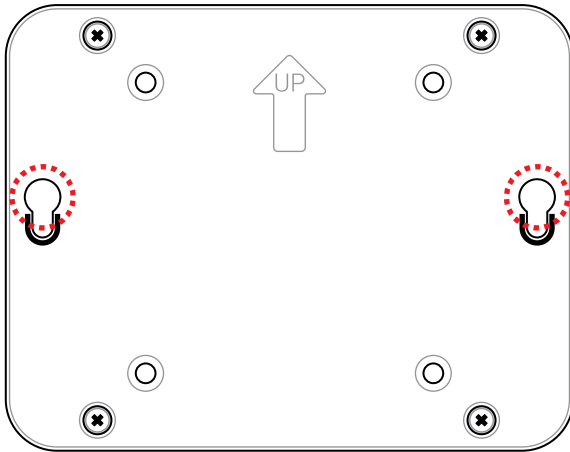

- Slide the NUC system downwards so that the screws are attached and secured to the VESA mount.

